

INSTRUCTION MANUAL



TX320 Transmitter

Revision: 6/16



Guarantee

This equipment is guaranteed against defects in materials and workmanship. We will repair or replace products which prove to be defective during the guarantee period as detailed on your invoice, provided they are returned to us prepaid. The guarantee will not apply to:

- Equipment which has been modified or altered in any way without the written permission of Campbell Scientific
- Batteries
- Any product which has been subjected to misuse, neglect, acts of God or damage in transit.

Campbell Scientific will return guaranteed equipment by surface carrier prepaid. Campbell Scientific will not reimburse the claimant for costs incurred in removing and/or reinstalling equipment. This guarantee and the Company's obligation thereunder is in lieu of all other guarantees, expressed or implied, including those of suitability and fitness for a particular purpose. Campbell Scientific is not liable for consequential damage.

Please inform us before returning equipment and obtain a Repair Reference Number whether the repair is under guarantee or not. Please state the faults as clearly as possible, and if the product is out of the guarantee period it should be accompanied by a purchase order. Quotations for repairs can be given on request. It is the policy of Campbell Scientific to protect the health of its employees and provide a safe working environment, in support of this policy a "Declaration of Hazardous Material and Decontamination" form will be issued for completion.

When returning equipment, the Repair Reference Number must be clearly marked on the outside of the package. Complete the "Declaration of Hazardous Material and Decontamination" form and ensure a completed copy is returned with your goods. Please note your Repair may not be processed if you do not include a copy of this form and Campbell Scientific Ltd reserves the right to return goods at the customers' expense.

Note that goods sent air freight are subject to Customs clearance fees which Campbell Scientific will charge to customers. In many cases, these charges are greater than the cost of the repair.



Campbell Scientific Ltd,
80 Hathern Road,
Shepshed, Loughborough, LE12 9GX, UK
Tel: +44 (0) 1509 601141
Fax: +44 (0) 1509 601091
Email: support@campbellsci.co.uk
www.campbellsci.co.uk

PLEASE READ FIRST

About this manual

Please note that this manual was originally produced by Campbell Scientific Inc. primarily for the North American market. Some spellings, weights and measures may reflect this origin.

Some useful conversion factors:

Area: 1 in ² (square inch) = 645 mm ²	Mass: 1 oz. (ounce) = 28.35 g 1 lb (pound weight) = 0.454 kg
Length: 1 in. (inch) = 25.4 mm 1 ft (foot) = 304.8 mm 1 yard = 0.914 m 1 mile = 1.609 km	Pressure: 1 psi (lb/in ²) = 68.95 mb
	Volume: 1 UK pint = 568.3 ml 1 UK gallon = 4.546 litres 1 US gallon = 3.785 litres

In addition, while most of the information in the manual is correct for all countries, certain information is specific to the North American market and so may not be applicable to European users.

Differences include the U.S standard external power supply details where some information (for example the AC transformer input voltage) will not be applicable for British/European use. *Please note, however, that when a power supply adapter is ordered it will be suitable for use in your country.*

Reference to some radio transmitters, digital cell phones and aerials may also not be applicable according to your locality.

Some brackets, shields and enclosure options, including wiring, are not sold as standard items in the European market; in some cases alternatives are offered. Details of the alternatives will be covered in separate manuals.

Part numbers prefixed with a “#” symbol are special order parts for use with non-EU variants or for special installations. Please quote the full part number with the # when ordering.

Recycling information



At the end of this product's life it should not be put in commercial or domestic refuse but sent for recycling. Any batteries contained within the product or used during the products life should be removed from the product and also be sent to an appropriate recycling facility.

Campbell Scientific Ltd can advise on the recycling of the equipment and in some cases arrange collection and the correct disposal of it, although charges may apply for some items or territories.

For further advice or support, please contact Campbell Scientific Ltd, or your local agent.



Campbell Scientific Ltd, 80 Hathern Road, Shepshed, Loughborough, LE12 9GX, UK
Tel: +44 (0) 1509 601141 Fax: +44 (0) 1509 601091
Email: support@campbellsci.co.uk
www.campbellsci.co.uk

Precautions

DANGER — MANY HAZARDS ARE ASSOCIATED WITH INSTALLING, USING, MAINTAINING, AND WORKING ON OR AROUND **TRIPODS, TOWERS, AND ANY ATTACHMENTS TO TRIPODS AND TOWERS SUCH AS SENSORS, CROSSARMS, ENCLOSURES, ANTENNAS, ETC.** FAILURE TO PROPERLY AND COMPLETELY ASSEMBLE, INSTALL, OPERATE, USE, AND MAINTAIN TRIPODS, TOWERS, AND ATTACHMENTS, AND FAILURE TO HEED WARNINGS, INCREASES THE RISK OF DEATH, ACCIDENT, SERIOUS INJURY, PROPERTY DAMAGE, AND PRODUCT FAILURE. TAKE ALL REASONABLE PRECAUTIONS TO AVOID THESE HAZARDS. CHECK WITH YOUR ORGANIZATION'S SAFETY COORDINATOR (OR POLICY) FOR PROCEDURES AND REQUIRED PROTECTIVE EQUIPMENT PRIOR TO PERFORMING ANY WORK.

Use tripods, towers, and attachments to tripods and towers only for purposes for which they are designed. Do not exceed design limits. Be familiar and comply with all instructions provided in product manuals. Manuals are available at www.campbellsci.eu or by telephoning +44(0) 1509 828 888 (UK). You are responsible for conformance with governing codes and regulations, including safety regulations, and the integrity and location of structures or land to which towers, tripods, and any attachments are attached. Installation sites should be evaluated and approved by a qualified engineer. If questions or concerns arise regarding installation, use, or maintenance of tripods, towers, attachments, or electrical connections, consult with a licensed and qualified engineer or electrician.

General

- Prior to performing site or installation work, obtain required approvals and permits. Comply with all governing structure-height regulations, such as those of the FAA in the USA.
- Use only qualified personnel for installation, use, and maintenance of tripods and towers, and any attachments to tripods and towers. The use of licensed and qualified contractors is highly recommended.
- Read all applicable instructions carefully and understand procedures thoroughly before beginning work.
- Wear a **hardhat** and **eye protection**, and take **other appropriate safety precautions** while working on or around tripods and towers.
- **Do not climb** tripods or towers at any time, and prohibit climbing by other persons. Take reasonable precautions to secure tripod and tower sites from trespassers.
- Use only manufacturer recommended parts, materials, and tools.

Utility and Electrical

- **You can be killed** or sustain serious bodily injury if the tripod, tower, or attachments you are installing, constructing, using, or maintaining, or a tool, stake, or anchor, come in **contact with overhead or underground utility lines.**
- Maintain a distance of at least one-and-one-half times structure height, or 20 feet, or the distance required by applicable law, **whichever is greater**, between overhead utility lines and the structure (tripod, tower, attachments, or tools).
- Prior to performing site or installation work, inform all utility companies and have all underground utilities marked.
- Comply with all electrical codes. Electrical equipment and related grounding devices should be installed by a licensed and qualified electrician.

Elevated Work and Weather

- Exercise extreme caution when performing elevated work.
- Use appropriate equipment and safety practices.
- During installation and maintenance, keep tower and tripod sites clear of un-trained or non-essential personnel. Take precautions to prevent elevated tools and objects from dropping.
- Do not perform any work in inclement weather, including wind, rain, snow, lightning, etc.

Maintenance

- Periodically (at least yearly) check for wear and damage, including corrosion, stress cracks, frayed cables, loose cable clamps, cable tightness, etc. and take necessary corrective actions.
- Periodically (at least yearly) check electrical ground connections.

WHILE EVERY ATTEMPT IS MADE TO EMBODY THE HIGHEST DEGREE OF SAFETY IN ALL CAMPBELL SCIENTIFIC PRODUCTS, THE CUSTOMER ASSUMES ALL RISK FROM ANY INJURY RESULTING FROM IMPROPER INSTALLATION, USE, OR MAINTENANCE OF TRIPODS, TOWERS, OR ATTACHMENTS TO TRIPODS AND TOWERS SUCH AS SENSORS, CROSSARMS, ENCLOSURES, ANTENNAS, ETC.

Table of Contents

PDF viewers: These page numbers refer to the printed version of this document. Use the PDF reader bookmarks tab for links to specific sections.

1. Introduction	1
2. Precautions	1
3. Initial Inspection	1
3.1 Ships With List	1
4. QuickStart	2
4.1 Step 1 – Configure the TX320	2
4.1.1 Accessing <i>DevConfig</i>	2
4.1.2 Setting Editor Configuration	3
4.1.3 Setting Editor GPS	5
4.2 Step 2 – Program the Datalogger	5
4.3 Step 3 – Install the Data Collection Platform (DCP)	6
5. Overview	11
5.1 GOES System	12
5.1.1 Orbit	12
5.1.2 NESDIS and Transmit–Windows	12
5.1.3 Data Retrieval	13
6. Specifications	13
7. Installation	15
7.1 Field Site Requirements	15
7.2 TX320 Functions	15
7.2.1 LED Function	15
7.2.2 Communication Ports.....	15
7.2.2.1 CS I/O Port	15
7.2.2.2 RS-232 Port.....	16
7.2.2.3 USB Port	16
7.2.3 RF Connectors	16
7.2.3.1 RF Transmission Connector	16
7.2.3.2 GPS Connector	16
7.2.4 Power Connector.....	16
7.3 Transmission Antenna.....	17
7.4 GPS Antenna.....	17
7.4.1 How the GPS Signal is Acquired and Used.....	17
7.4.2 GPS Antenna Location	18
7.5 CRBasic Programming	18
7.5.1 GoesData()	18
7.5.1.1 Result Code	18
7.5.1.2 Data Table	18
7.5.1.3 Table Option.....	18

7.5.1.4	Buffer Control	19
7.5.1.5	Data Format	19
7.5.1.6	GOESData() Example	20
7.5.2	GoesStatus()	21
7.5.2.1	GoesStatus Read Time	21
7.5.2.2	GoesStatus Read Status	22
7.5.2.3	GoesStatus Read Last Message Status	22
7.5.2.4	GoesStatus Read Error Register	23
7.5.3	GoesGPS	24
7.5.4	GoesSetup	24
7.5.4.1	Result Code	25
7.5.4.2	Platform ID	25
7.5.4.3	Window	25
7.5.4.4	Timed Channel	25
7.5.4.5	Timed Baud Rate	25
7.5.4.6	Random Channel	25
7.5.4.7	Random Baud Rate	25
7.5.4.8	Timed Interval	25
7.5.4.9	Timed Offset	25
7.5.4.10	Random Offset	26
7.5.4.11	GOESSetup() Example	26
7.6	Edlog Programming	26
7.6.1	Deciding How Much Data will be Transmitted and When	26
7.6.2	Deciding What Data Format to Use	27
7.6.3	Managing Data, Writing More Data than Will Be Transmitted	27
7.6.4	Sending Data to the Transmitter (P126)	27
7.6.4.1	Buffer Control	28
7.6.4.2	Data Format	28
7.6.4.3	P126 Result Codes	28
7.6.5	Read Status and Diagnostic Information from the TX320	29
7.6.5.1	P127, Command 0: Read Time	30
7.6.5.2	P127, Command 1: Read Status	30
7.6.5.3	P127, Command 2: Read Last Message Status	31
7.6.5.4	P127, Command 3: Transmit Random Message	31
7.6.5.5	P127, Command 4: Read TX320 Error Registers	32
7.6.5.6	P127, Command 5: Clear TX320 Error Registers	32
7.6.5.7	P127, Command 6: Return TX320 to Online Mode	32
7.6.6	Edlog Programming Examples	32

8. Troubleshooting/Diagnostics.....33

8.1	Diagnostics Button	33
8.2	Result Codes	33
8.3	Error Codes	35
8.4	Using Device Configuration Utility for Troubleshooting/ Testing....	38
8.4.1	Setting Editor GPS	38
8.4.2	Setting Editor Status	39
8.4.3	Terminal	39

Appendices

A. Information on Eligibility and Getting Onto the GOES System.....A-1

A.1	Eligibility	A-1
A.2	Acquiring Permission.....	A-1
B.	Data Conversion Computer Program (written in BASIC)	B-1
C.	Antenna Orientation Computer Program (written in BASIC)	C-1
D.	GOES DCS Transmit Frequencies	D-1
E.	High Resolution 18-Bit Binary Format.....	E-1
F.	Extended ASCII Command Set.....	F-1
F.1	Command Interface	F-1
F.1.1	Port Interfaces	F-1
F.1.1.1	RS-232 Details	F-1
F.1.1.2	Command Protocol.....	F-1
F.1.1.3	Command Access Level.....	F-2
F.2	General Configuration Commands	F-2
F.2.1	Clock Read/Set.....	F-2
F.2.2	Replacement Character Read/Set.....	F-3
F.2.3	Save Configuration	F-3
F.2.4	Restore Configuration	F-3
F.2.5	Restore Default Configuration	F-3
F.2.6	Enable Transmissions	F-4
F.2.7	Disable Transmissions	F-4
F.2.8	Read Configuration.....	F-4
F.2.9	Enable Technician Command Mode	F-5
F.2.10	Enable User Command Mode	F-5
F.2.11	Set GPS Fix Interval	F-5
F.3	GOES Transmission Configuration Commands	F-5
F.3.1	Set GOES DCP Platform ID	F-6
F.3.2	Set Self-Timed Transmission Channel Number.....	F-6
F.3.3	Set Self-Timed Transmission Bit Rate.....	F-6
F.3.4	Set Self-Timed Transmission Interval.....	F-6
F.3.5	Set Self-Timed transmission First Transmission Time	F-7
F.3.6	Set Self-Timed Transmission Transmit Window Length.....	F-7
F.3.7	Enable or Disable Self-Timed Transmission Message Centering	F-7
F.3.8	Enable or Disable Self-Timed Buffer Empty Message	F-7
F.3.9	Set Self-timed Transmission Preamble Length	F-8
F.3.10	Set Self-Timed Transmission Interleaver Mode	F-8
F.3.11	Set Self-Timed Transmission Data Format.....	F-8
F.3.12	Set Random Transmission Channel Number	F-8
F.3.13	Set Random Transmission Bit Rate	F-9
F.3.14	Set Random Transmission Interval	F-9
F.3.15	Set Random Transmission Randomizing Percentage.....	F-9
F.3.16	Set Random Transmission Repeat Count.....	F-9
F.3.17	Enable or Disable Random Transmission Message Counter ..	F-10
F.4	Data Buffer Loading Commands	F-10
F.4.1	Load Self-Timed Transmission Buffer	F-10

F.4.2	Read Number of Bytes in the Self-Timed Transmission Buffer.....	F-11
F.4.3	Read the Maximum Self-Timed Message Length.....	F-11
F.4.4	Clear Self-Timed Transmission Buffer	F-11
F.4.5	Load Random Transmission Buffer	F-11
F.4.6	Read Length of the Message in the Random Transmission Buffer.....	F-12
F.4.7	Read the Maximum Random Message Length.....	F-12
F.4.8	Clear Random Transmission Buffer	F-12
F.5	Status and Other Commands.....	F-12
F.5.1	Read Version Information.....	F-13
F.5.2	Read Transmission Status	F-13
F.5.3	Read Last Transmission Status.....	F-13
F.5.4	Read GPS Status.....	F-14
F.5.5	Read GPS Position	F-15
F.5.6	Read Audit Log	F-15
F.5.7	Read Forward Power.....	F-15
F.5.8	Read Reflected Power	F-16
F.5.9	Read Power Supply	F-16
F.5.10	Read TCXO Temperature	F-16
F.5.11	Read Measured Frequency	F-16

G. Meteosat Transmit Frequencies..... G-1

Figures

4-1.	Ports used for computer connection	2
4-2.	Settings Editor Configuration in Device Configuration Utility	4
4-3.	Yagi antenna.....	6
4-4.	Alignment Tab in Device Configuration Utility.....	7
4-5.	Exploded view of the GPS antenna mounted to a crossarm via the CM220.	8
4-6.	GPS antenna mounted to a crossarm via the CM220	8
4-7.	Antenna connectors	9
4-8.	TX320 connectors	10
4-9.	DCP enclosure.....	11
5-1.	Major components of the GOES/DCP system (GPS antenna and solar panel not shown)	13
8-1.	Settings Editor Status in Device Configuration Utility.....	37
8-2.	Settings Editor GPS in Device Configuration Utility	38

Tables

7-1.	GoesStatus Command 0: Read Time.....	21
7-2.	GoesStatus Command 1: Read Status	22
7-3.	GoesStatus Command 2: Read Last Message Status.....	23
7-4.	GoesStatus Command 4: Read TX320 Error Registers.....	23
7-5.	P127 Result Codes	30
7-6.	P127 Command 0: Read Time	30
7-7.	P127 Command 1: Read Status	30
7-8.	P127 Command 2: Read Last Message Status	31
7-9.	P127 Command 3: Initiate Random Transmission.....	31
7-10.	P127 Command 4: Read TX320 Error Registers	32
7-11.	P127 Command 5: Clear Error Registers	32
7-12.	P127 Command 6: Force Online Mode.....	32

8-1.	Result Codes Indicating Communication Problems.....	34
8-2.	GoesSetup and GoesData Runtime Result Codes	35
8-3.	Error Codes	35
D-1.	GOES DCPRS Transmit Frequencies Certification Standard 1.0 ...	D-1
D-2.	GOES DCPRS Transmit Frequencies Certification Standard 2.0 ...	D-4

CRBasic Examples

7-1.	GOESData().....	20
7-2.	GOESSetup()	26

TX320 Transmitter

1. Introduction

The TX320 is a high data rate transmitter that supports one-way communication, via satellite, from a Campbell Scientific datalogger to a ground receiving station. Satellite telemetry offers a convenient telecommunication alternative for field stations where phone lines or RF systems are impractical.

Before installing the TX320, please study

- Section 2, *Precautions* (p. 1)
- Section 3, *Initial Inspection* (p. 1)
- Section 4, *QuickStart* (p. 2)

Additional information is provided in the following sections.

2. Precautions

- Although the TX320 is rugged, it should be handled as a precision scientific instrument.
- A proper antenna connection is required before transmission occurs. Failure to use a properly matched antenna cable and antenna may cause permanent damage to the RF amplifiers.

3. Initial Inspection

- Upon receipt of the TX320, inspect the packaging and contents for damage. File damage claims with the shipping company.
- Check the ships with list to ensure all components are received. Ships with list is provided in Section 3.1, *Ships With List* (p. 1).

3.1 Ships With List

- (1) 17648 USB Cable
- (1) SC12 Serial Cable
- (1) 18133 Power Cable (includes one 18889 7.5 A Fast-Blow Fuse)
- (4) 505 #6-32 x .375 Pan Phillips Screws
- (4) Grommets

4. QuickStart

4.1 Step 1 – Configure the TX320

Use our Device Configuration Utility (*DevConfig*) to enter the required National Environmental Satellite Data and Information Service (NESDIS) information that is unique to each Data Collection Platform (DCP). *DevConfig* must be version 2.02 or higher. The TX320 has non-volatile memory to store the setup information.

NOTE Before February 2012 the TX320 was configured using *SatCommand* instead of *DevConfig*. *DevConfig* is more intuitive, included with our datalogger support software, and available at no charge from our website.

4.1.1 Accessing *DevConfig*

The following are the steps required for accessing *DevConfig*:

- Connect the TX320 to the PC. A standard 9-pin serial cable is used to connect the TX320's RS-232 port to the PC's RS-232 port. Alternatively, the transmitter can be connected to the PC's USB port via the 17648 USB cable (see FIGURE 4-1).

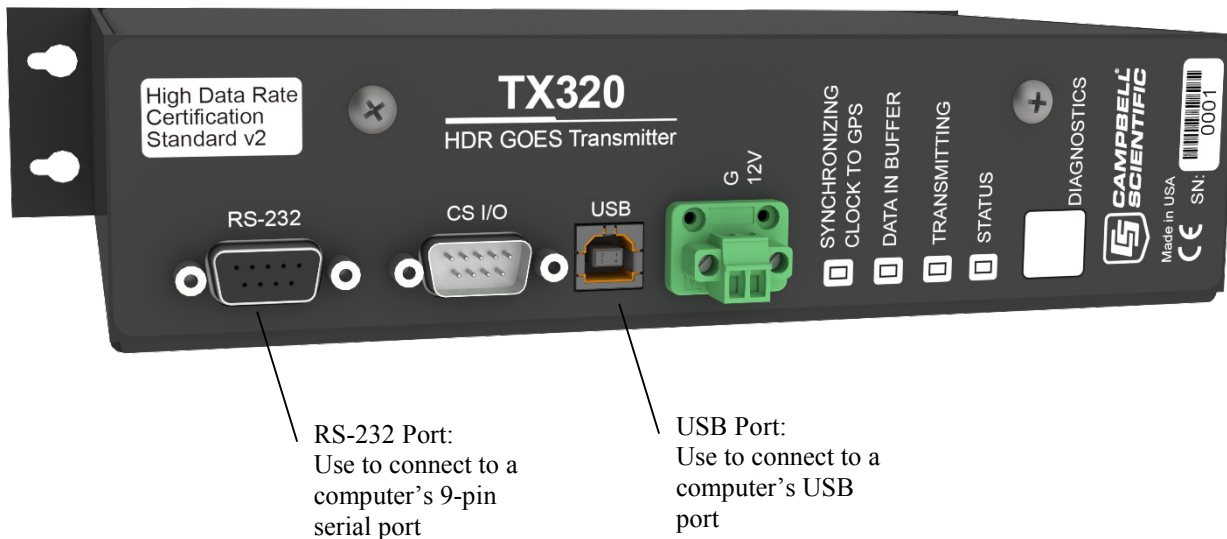

FIGURE 4-1. Ports used for computer connection

- Connect the TX320 to a +12 Vdc power source.
- In order to obtain GPS coordinates (used for aiming the satellite antenna), the GPS antenna will also need to be connected to the transmitter.
- Click on **TX320/TX312** for the device type in *DevConfig*.
- Select the port matching the **COM** or **USB** port on the PC in which the transmitter is connected.
- Click on the **Connect** button on the bottom left of the *DevConfig* screen.

4.1.2 Setting Editor | Configuration

An example of parameters entered in the **Configuration** tab is provided in FIGURE 4-2.

NESDIS Platform ID: Type in your NESDIS-assigned ID number. This is an 8-digit hex number.

Self-Timed Transmission Channel: Select the NESDIS-assigned self-timed transmission channel. For 1200-baud channels, the formal channel designation is the channel number followed by the letter A, for example: 99A. Setting the channel number to a value of zero will disable timed transmissions.

Self-Timed Transmission Bit Rate: Select the NESDIS-assigned channel bit rate (baud rate). This value will be either 300 or 1200 for a CS-2 device.

Self-Timed Transmission Interval: Enter the interval between timed transmissions (specified as dd:hh:mm:ss). The default value of 00:01:00:00 will transmit the data every hour. The valid range for this setting is 00:00:05:00 to 30:23:59:59.

Self-Timed Transmission First Time: Enter an offset from the Self-Timed Transmission Interval that specifies when the first transmission will take place; must be less than the Self-Timed Transmission Interval. Example: Self-Timed Transmission Interval = 00:01:00:00 (1 hour) and the Self-Timed Transmission First Time = 00:15:00 (15 min). The transmission pattern starting at midnight will be the following 00:15:00, 01:15:00, 02:15:00...23:15:00.

Self-Timed Transmission Window Length(s): Enter the NESDIS-assigned length of the self-timed transmission window in units of seconds.

Self-Timed Transmission Data Format: Specify whether self-timed data will be transmitted in ASCII, binary, or pseudo binary formats. This setting does not change the format of the data; it only changes the flag word. The datalogger program determines the data format and should match the format chosen for this setting.

Self-Timed Preamble Length: The default value of **Short** must be used for CS-2 devices.

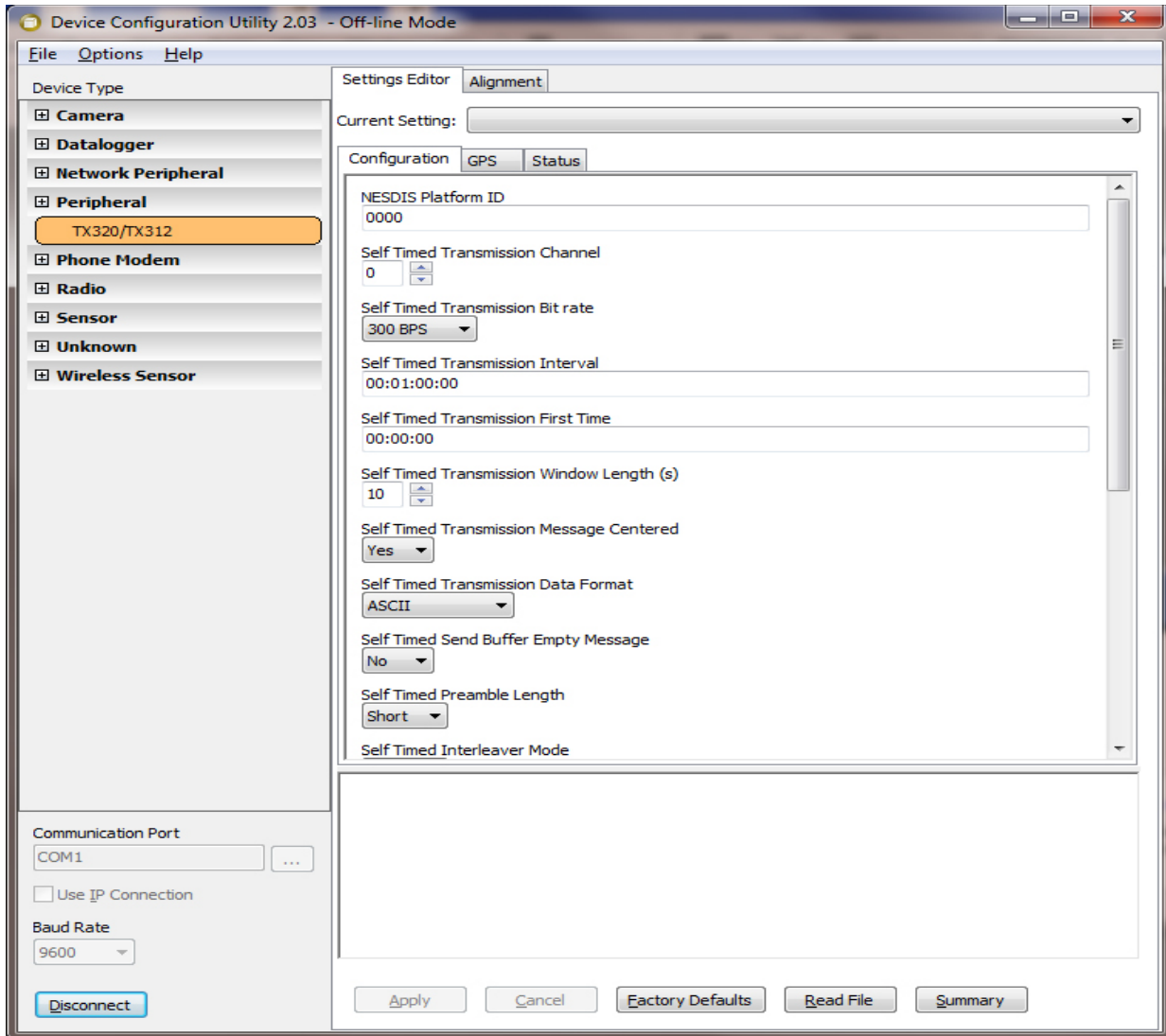

FIGURE 4-2. Settings Editor | Configuration in Device Configuration Utility

NOTE

If NESDIS has not assigned a Random Channel, the following parameters do not apply.

Random Transmission Channel: Select the NESDIS-assigned random transmission channel. Setting the channel number to a value of zero will disabled random transmissions.

Random Transmission Bit Rate: Select the NESDIS-assigned channel bit rate (baud rate). This value will be either 300 or 1200 for a CS-2 device.

Random Transmission Window Length(s): Specify the randomizing interval in units of minutes. This value is the interval at which a random transmission will take place if there is data in the random buffer. The actual interval will be random but will, on average, occur at this rate.

Random Transmission Data Format: Specify whether random data will be transmitted in ASCII, binary, or pseudo binary formats. This setting does not change the format of the data; it only changes the flag word. The datalogger program determines the data format and should match the format chosen for this setting.

NOTE The default values for the remaining parameters in **Settings Editor | Configuration** can be used for many applications. Refer to the *DevConfig* help for details about the parameters.

Click **Apply** after changing settings.

4.1.3 Setting Editor | GPS

GPS Fix Interval: Enter the interval at which the transmitter will attempt to get a GPS position fix (specified as hh:mm:ss). The GPS fix interval **MUST NOT** coincide with the self-timed transmission interval. A GPS fix event must occur at least two minutes on either side of a self-timed transmission. Click **Apply** after changing the setting.

NOTE The default value of 00:00:00 disables periodic GPS position fixes although these will still occur at power up and every 24 hours as a side effect of the daily automatic OCXO calibration.

4.2 Step 2 – Program the Datalogger

The CRBasic program needs to include the **GoesData()** instruction, which tells the datalogger to send data to the transmitter. Refer to Section 7.5.1, *GoesData()* (p. 18), for programming details and example.

4.3 Step 3 – Install the Data Collection Platform (DCP)

1. Mount the 25316 Yagi antenna to a pole or mast by using the U-bolts included with the antenna mount (see FIGURE 4-3).

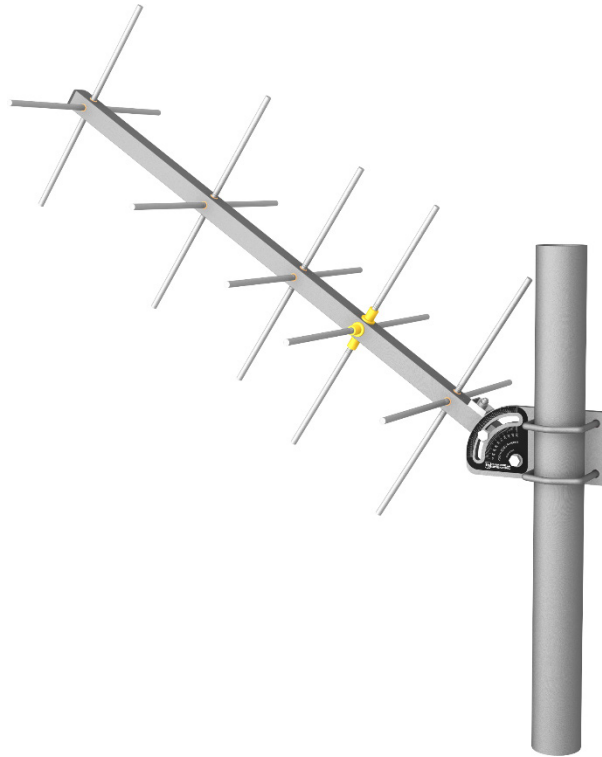

FIGURE 4-3. Yagi antenna

2. Aim the Yagi antenna at the spacecraft; azimuth and elevation angle positions are included on the bracket label. The **Alignment** tab in *DevConfig* can be used to determine the correct coordinates for the azimuth and elevation (see FIGURE 4-4). In the **Alignment** tab, select either the **East** or **West** satellite, enter the transmitter's **Latitude**, **Longitude**, **Altitude**, and the **Magnetic Declination**. The correct angles are then displayed in the lower panel.

NOTE Refer to Section 4.1.1, *Accessing DevConfig* (p. 2), for information about accessing *DevConfig*. The transmitter's internal GPS can be used to acquire the azimuth and elevation information. To use the internal GPS device, connect the GPS antenna (see FIGURE 4-7). The information will be listed in the GPS tab of *DevConfig*.

NOTE Additional information about the Yagi antenna is provided in Section 7.3, *Transmission Antenna* (p. 17).

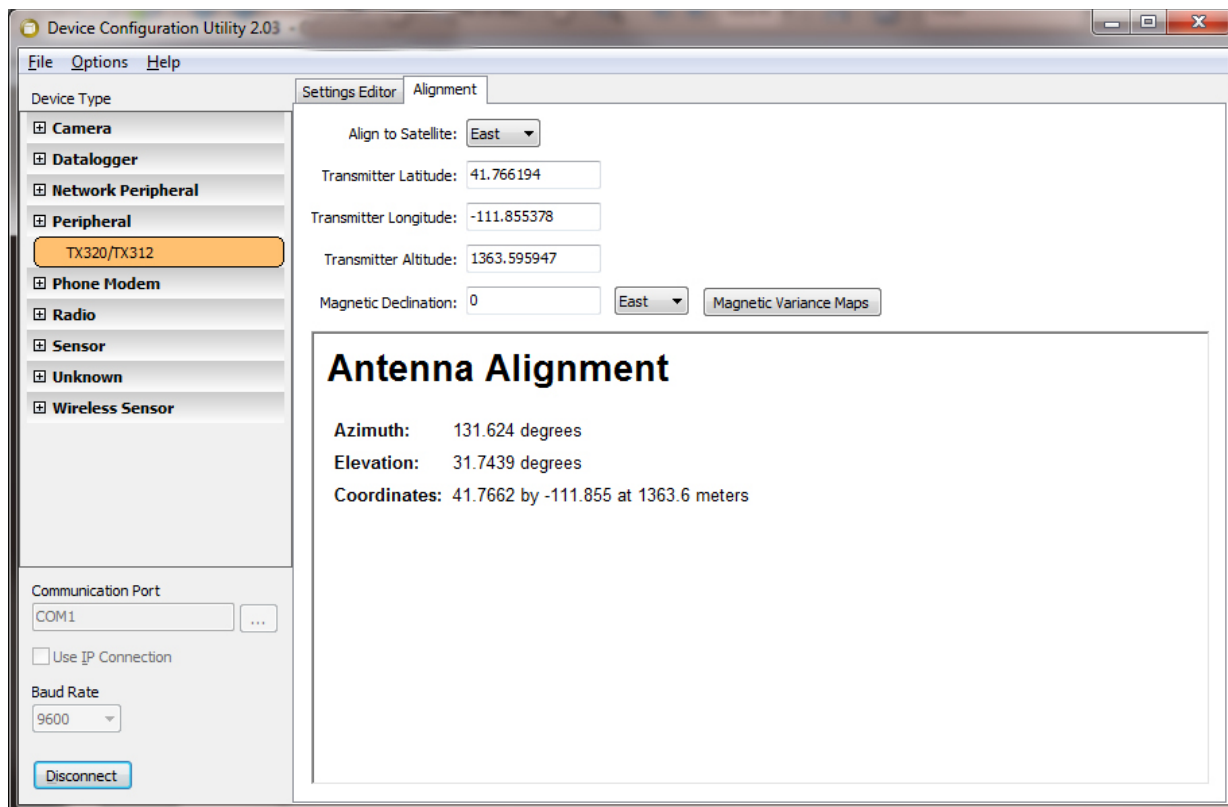

FIGURE 4-4. Alignment Tab in Device Configuration Utility

3. Insert the 7623 3/4 IPS aluminum pipe into the GPS antenna (see FIGURE 4-5).
4. Mount the 7623 3/4 IPS aluminum pipe to a crossarm via a CM220 mount or NU-RAIL fitting. FIGURE 4-5 and FIGURE 4-6 show the GPS antenna mounted to a crossarm using a CM220 mount. The ideal location for the GPS antenna is above everything, with the shortest cable possible. Refer to Section 7.4, *GPS Antenna* (p. 17), for additional information about the GPS antenna.

CAUTION

The GPS antenna will not receive a GPS signal through steel roofs or steel walls. Concrete might also be a problem. Heavy foliage, snow, and ice will attenuate the GPS signal.



FIGURE 4-5. Exploded view of the GPS antenna mounted to a crossarm via the CM220.



FIGURE 4-6. GPS antenna mounted to a crossarm via the CM220

5. Mount the TX320, CH100 or CH200 regulator, BP12 or BP24 battery pack, and CR1000 to the backplate of an ENC16/18 enclosure.
6. Mount the enclosure and solar panel to the pole or tripod.
7. Connect the COAXNTN cable to the Yagi antenna. Then route the COAXNTN cable through the enclosure conduit and connect it to the TX320 connector labeled RF Out (see FIGURE 4-7 and FIGURE 4-8).
8. Connect the TNC connector of the 18017-L cable to the GPS antenna. Route the 18017-L cable through the enclosure conduit and connect it to the TX320 connector labeled GPS (see FIGURE 4-7 and FIGURE 4-8).
9. Wire the TX320, CH100 or CH200 regulator, BP12 battery, and CR1000 according to FIGURE 4-8 and FIGURE 4-9.
10. Route the solar panel cable through the enclosure conduit and connect the red and black wires to the CHG terminals on the CH100 or CH200.

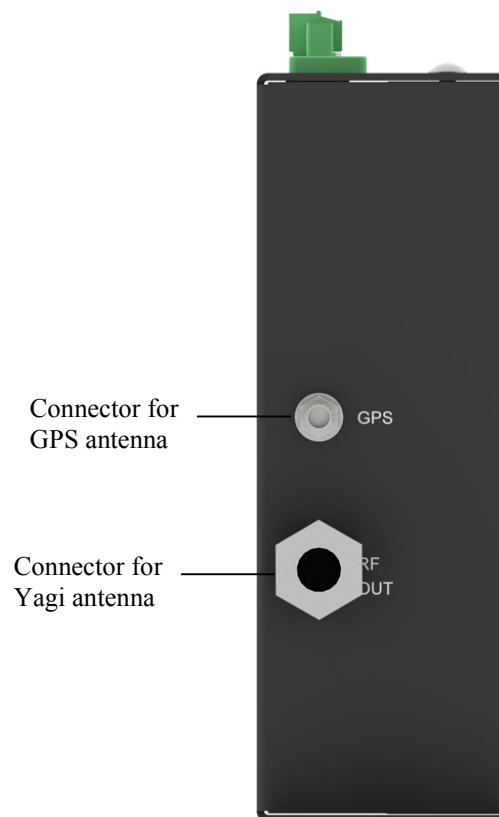

FIGURE 4-7. Antenna connectors

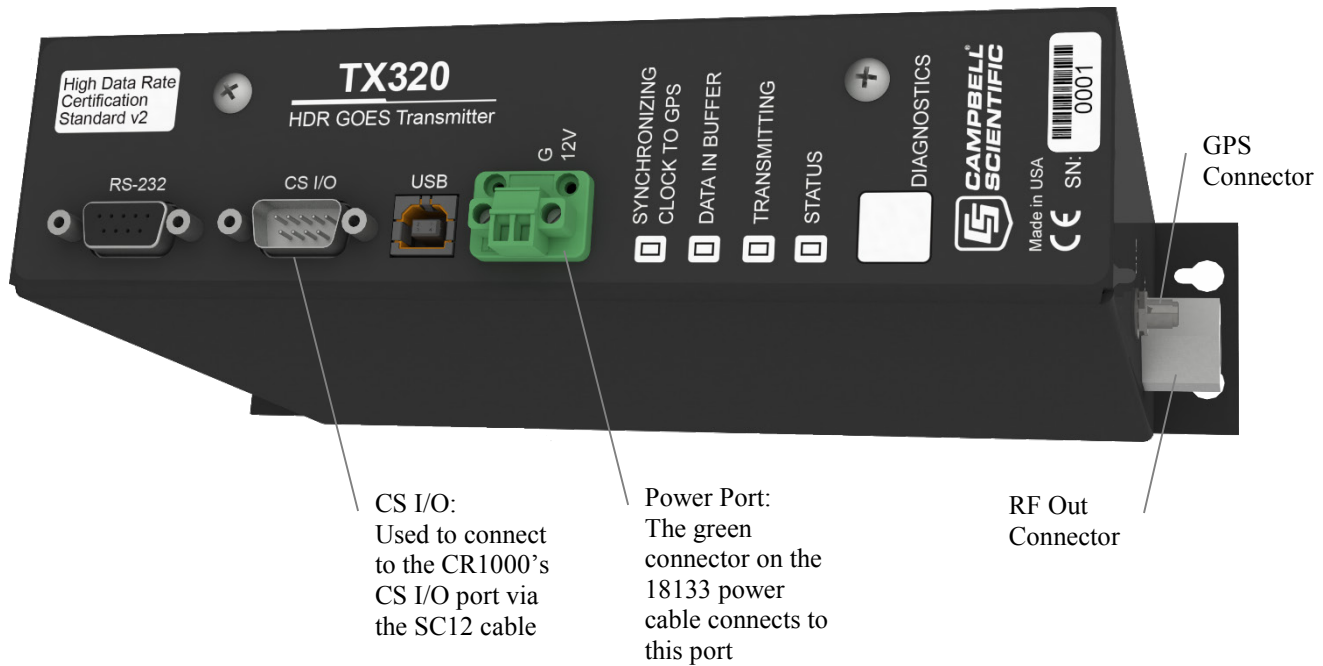

FIGURE 4-8. TX320 connectors

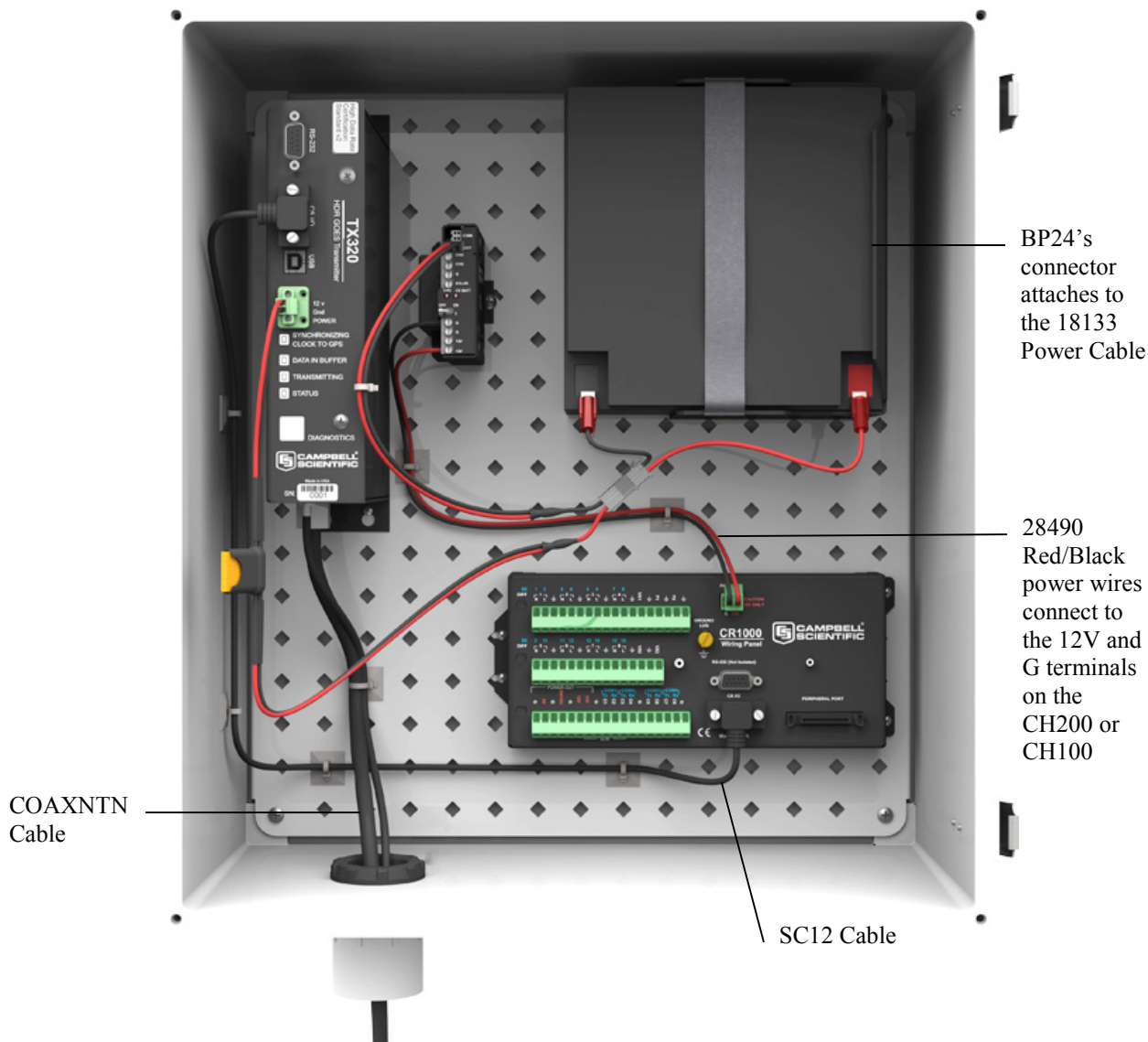

FIGURE 4-9. DCP enclosure

5. Overview

The TX320 uses non-volatile memory to store configuration information, such as platform ID, transmission baud rate, channel number, scheduled transmission time, offset time and message window length. The TX320 also has a 15.7 kB RAM buffer for scheduled transmissions and a buffer for random transmissions. The clock is maintained with a GPS receiver.

The TX320 transmitters currently support the:

- GOES Data Collection Platform Radio Set (DCPRS) Certification Standards at 300 bps and 1200 bps, version 2, effective date: June 2009 (also known as CS2)
- 300/1200 bps DCPRS Certification Standard version 1.0b - March 2000

The TX320 supports High Data Rate specifications. The TX320 includes the following communication ports:

- CS I/O port for Campbell dataloggers
- RS-232 port for dataloggers and PC communication
- USB port for PC communications

The CS I/O port is a Campbell Scientific Synchronous Device for Communication (SDC) port, address 4.

NOTE The 21X and CR7 dataloggers do not support SDC or the TX320.

5.1 GOES System

Appendix A, *Information on Eligibility and Getting Onto the GOES System (p. A-1)*, provides information about getting onto the GOES system and eligibility.

5.1.1 Orbit

The TX320 transmitter sends data via Geostationary Operational Environmental Satellites (GOES). GOES satellites have orbits that coincide with the Earth's rotation, allowing each satellite to remain above a specific region. This allows a user to point the GOES antenna at a fixed position in the sky.

There are two satellites, GOES East and GOES West. GOES East is located at 75° West longitude and GOES West is located 135° West longitude. Both satellites are located over the equator. Within the United States, odd numbered channels are assigned to GOES East. Only even numbered channels are assigned to GOES West. Channels used outside the United States are assigned to either spacecraft.

5.1.2 NESDIS and Transmit–Windows

GOES is managed by the National Environmental Satellite Data Information Service (NESDIS). NESDIS assigns the platform ID, uplink channel number, and self-timed or random transmit windows. Self-timed windows allow data transmission only during a predetermined time frame (typically 10 seconds every hour). The self-timed data is erased from the transmitter's buffer after each transmission, random data is not. Random windows are for critical applications (for example, flood reporting) and allow transmission immediately after a threshold has been exceeded. The transmission is then randomly repeated to ensure it is received. A combination of self-timed and random transmission can be executed by the TX320.

5.1.3 Data Retrieval

Data retrieval via the TX320 and the GOES system is illustrated in FIGURE 5-1. The DAPS User Interface Manual, provided by NOAA/ NESDIS, describes the process of retrieving the data from the NESDIS ground station. The data are in the form of three-byte ASCII (see Appendix B, *Data Conversion Computer Program (written in BASIC) (p. B-1)*, for a computer program that converts the data to decimal). You can also retrieve data directly from the NESDIS ground station via DOMSAT, LRGs, or LRIT. DOMSAT is only practical for organizations with many GOES users. Contact NESDIS for more information (www.noaasis.noaa.gov/DCS).

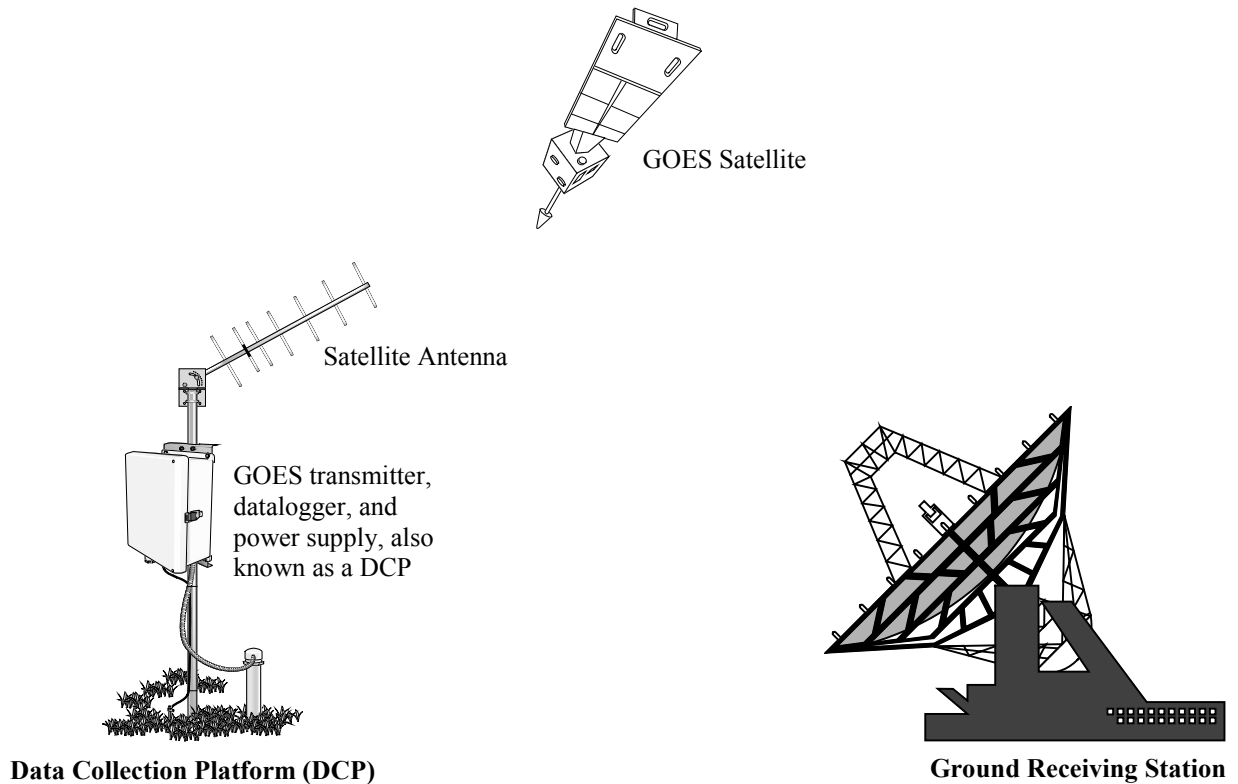

FIGURE 5-1. Major components of the GOES/DCP system (GPS antenna and solar panel not shown)

6. Specifications

On-board Memory:	Non-volatile flash for setup parameters 16 kB for data
Transmission Data Rates:	300 and 1200 bps
Operating Voltage Range:	10.8 to 16 Vdc
25316 Transmit Antenna:	11 dBi gain, right hand circular polarization, type N female connector, wind load of ~100 knots
RF Output:	30 to 38 dBm

Frequency Range:	401.701 MHz to 402.1 MHz
Frequency Stability	
Initial Accuracy:	±20 Hz disciplined to GPS
Short-Term Drift:	±0.04 Hz/s
Aging:	±0.1 PPM/year
Vcc + Temperature:	±0.1 PPM
Channel Bandwidth:	1.5 kHz (300 bps); 3 kHz (1200 bps)
Time Keeping:	Initial setting accuracy: ± 100 µs synchronized to GPS; Drift ± 10 ms/day over operating temperature range; GPS scheduled updates are one at power up and once per day thereafter. Once every 28 days required for continual operation.
GPS Antenna:	3.3 V active; SMA female connector
RS-232 Serial Port	
Signal Levels:	RS-232C
Connector:	DB9F
DCE Command protocols:	ASCII, binary, field diagnostics, dataloggers with RS-232 port
USB Port	
Connector:	Type B
Command protocols:	ASCII, binary, field diagnostics
CS I/O Port	
Signal Levels:	TTL, Connector DB9M
Command Protocol:	Campbell Scientific Synchronous Device Communication, address 4, Binary Command, Campbell Scientific Dataloggers
Environmental:	Operating: -40° to 60°C; Storage -55° to 70°C; 0 to 99% RH, non-condensing
Dimensions (with connectors):	17.0 H x 24.9 L x 5.3 W cm (6.7 in x 10.6 in x 2.1 in)
Dimensions (without connectors):	15.8 H x 24.9 L x 5.3 W cm (6.2 in x 9.8 in x 2.1 in)
Weight:	1.02 kg (2.25 lb)
Emission Designators	
@ 300 bps:	300HG1D
@ 1200 bps:	1K20G1D
Current Drain @12 Vdc	
Idle or Sleep:	5 mA
Transmission:	2.6 A
GPS Fix:	80 mA to 15 mA per day

7. Installation

7.1 Field Site Requirements

The TX320 has two siting requirements for proper operation. The GPS antenna must have a clear view of most of the sky. The transmission antenna must have a clear view of the spacecraft. Other requirements are not specific to the TX320, but are mentioned here anyway. The TX320 must be mounted in an enclosure that will protect it from the environment, including condensation. Most GOES systems are powered by a battery that is charged by a solar panel. The solar panel must have a clear view of the southern sky. Pay special attention to winter sun angles.

7.2 TX320 Functions

7.2.1 LED Function

The TX320 has four LEDs used to indicate the state of the TX320 transmitter.

When power is first applied to the TX320, the four LEDs will cycle through quickly, then the **SYNCHRONIZING CLOCK TO GPS** LED will light for 15 minutes.

If there are data in a buffer waiting for transmission time, the **DATA IN BUFFER** LED will light.

During transmission, the **TRANSMITTING** LED will light.

The **STATUS** LED will only light after the **DIAGNOSTICS** button has been depressed. Press and hold the **DIAGNOSTICS** button for about 2 seconds. The **STATUS** LED will flash once to indicate the fail-safe has not been tripped. If the LED flashes twice, the fail-safe has tripped. To clear the fail-safe, press and hold the **DIAGNOSTICS** button for about 10 seconds.

7.2.2 Communication Ports

NOTE The CS I/O port and RS-232 port share the same hardware and therefore cannot be connected simultaneously. Presence of 12 V on the CS I/O port disables the RS-232 port and enables the CS I/O port.

7.2.2.1 CS I/O Port

The CS I/O port is an SDC port. The CS I/O port is specifically designed to work with Campbell Scientific SDC capable dataloggers. The CS I/O port is used by Campbell Scientific dataloggers to transfer data from the datalogger to the TX320 transmitter. The CS I/O SDC port allows other SDC devices and one modem enabled device to be connected to the same port at the same time. This SDC port will allow the TX320 transmitter, the RF500M RF modem and a phone modem to be connected to the datalogger serial port all at the same time. The CS I/O port is a DB9 male, voltage levels are TTL, SDC address 4, pin out is:

1, 3, 5 are not used
2 = Ground
4 = RXD (output)
6 = SDE (input)
7 = CLK (input)
8 = 12V (input)
9 = TXD (input)

7.2.2.2 RS-232 Port

The RS-232 port is a DB9 female connector configured as DCE. Only three pins are used, transmit on pin two, receive on pin three, and ground on pin five. Transmit is an output and receive is an input to the TX320.

The RS-232 port allows the transmitter to be connected to a PC's 9-pin serial port or to a datalogger's RS-232 port. Connection to a PC is required to configure the transmitter via *Device Configuration Utility*.

7.2.2.3 USB Port

The transmitter also has a type B USB port for connecting to a PC. Many newer computers only have USB ports. Configuration of the transmitter via *Device Configuration Utility* requires that the transmitter is connected to a PC.

7.2.3 RF Connectors

7.2.3.1 RF Transmission Connector

The TX320 uses the type N female connector for RF power out. This connector must have a proper antenna connection before transmission occurs. Failure to use a properly matched antenna cable and antenna may cause permanent damage to the RF amplifiers. The nominal impedance is 50 ohms, the frequency range is approximately 400 to 403 MHz. At 300 bps transmission rates, the nominal EIRP is 48 dBm with an 11 dBi gain antenna. At 1200 bps, the nominal EIRP is 52 dBm. CS-2 standards use lower transmit power.

7.2.3.2 GPS Connector

The GPS connector is an input to the TX320. Operation without an antenna connected will not cause damage, but the transmitter will not transmit without a valid GPS fix. The GPS connector is an SMA female. The GPS receiver uses an active 3.3 V antenna.

The TX320 transmitter uses the GPS receiver for two functions. The precise GPS time is used to ensure scheduled transmissions occur at the proper time. The one-second GPS synchronization pulse is used to ensure a precise, drift-free carrier frequency. See Section 7.4, *GPS Antenna* (p. 17), for more information regarding GPS and GPS antenna placement.

7.2.4 Power Connector

The TX320 power connector has two pins: ground and 12 V. The input power requirement is 10.8 to 16 Vdc at 3 amps. Because the TX320 can use up to 3 A, the power should be connected directly to the battery. An in-line 7 A fast blow fuse can be used to help protect the transmitter. The TX320 is shipped with a power cable that includes the fuse and a connector arrangement that allows the transmitter to pull power directly from the battery when using the CH200, CH100, PS100, or PS200 power supply.

With the potential for a 3000 mA current drain, the voltage drop along the battery power leads must be considered. The battery power leads are both wires that run from the battery to the power input connectors of the TX320. To calculate the voltage drop along the power leads, we must know the resistance of the wire and the length of the wire. Usually the resistance of the wire is listed as ohms per 1000 feet. As an example, a 24 AWG wire used by Campbell Scientific has a resistance of 23 ohms per 1000 feet. The length of the wire is the distance the wire travels from the battery to the transmitter multiplied by two. You must consider the current travels from the battery, to the transmitter, and back to the battery.

The TX320 will operate with a battery voltage range from 10.8 V to 16 V. A fully charged lead acid battery will have a voltage of about 12.5 V. If the battery is fully charged, a 1.7 V drop along the battery leads will stop the transmitter from transmitting. At 3 A, 1.7 V will be dropped with 0.566 ohms of resistance. Using the 24 AWG wire with 23 ohms resistance per 1000 ft, 24 ft of wire (battery power leads 12 ft long) will prevent transmission. A reliable system that will transmit without a perfect battery voltage will minimize voltage drop along the battery power leads. To minimize voltage drop, keep the battery power leads short. A five-foot power lead is a long power lead. If you must have a longer lead, use heavy wire. For power leads less than ten feet but more than five feet, use no smaller than 18 AWG.

7.3 Transmission Antenna

The TX320 transmission antenna is a right-hand circular polarized Yagi with 11 dBi gain. A bracket is included with the antenna for mounting to a mast or pole. The antenna is directional and should be aimed at the spacecraft. Both elevation and azimuth are unique to the location on the planet, and must be set. A poorly aimed antenna will cause a drop in signal strength or possibly prevent successful transmission.

The accuracy of the antenna aiming is not critical, but should be reasonably good. As a guide, if the antenna is aimed 20 degrees off the spacecraft, the received power will be half of a properly aimed antenna. Beyond 20 degrees, the received power drops off very quickly.

7.4 GPS Antenna

7.4.1 How the GPS Signal is Acquired and Used

The GPS receiver will acquire a complete GPS fix at power up and once a day. The TX320 transmitter will continue to operate normally for 28 days without a GPS fix.

The GPS signal is used for two functions. To keep track of time, four satellites are required. The second use of the GPS signal is to correct the oscillator frequency. The GPS receiver will output a very accurate 1-second pulse. The 1-second pulse is used to correct oscillator drift caused by changes in temperature and crystal aging.

The GPS is required for proper operation. After the transmitter is reset, or first powered up, it can't schedule a transmission until a GPS fix has been established or the internal clock has been manually set. After the first fix, the TX320 will acquire a GPS fix once a day. Each time the GPS system acquires a fix, the entire GPS almanac is downloaded, which requires about 15 minutes.

7.4.2 GPS Antenna Location

The GPS antenna mounts to the end of a crossarm via the 7623 3/4-in. IPS threaded pipe and a 1049 NU-RAIL fitting or CM220 mounting bracket. The ideal location for the GPS antenna is above everything, with the shortest cable possible. The GPS antenna will not receive the GPS signal through a steel roof or steel walls. Concrete will probably act like steel. Heavy foliage, snow, and ice will attenuate the GPS signal. The more of the sky the antenna has a clear unobstructed view of, the better the GPS performance. Better GPS performance will show up as less or no missed transmissions. Poor GPS antenna placement will increase the number of missed transmissions, or possibly stop all transmission.

7.5 CRBasic Programming

This section covers CRBasic programming concepts for the CR295(X), CR800, CR850, CR1000, CR3000, and CR5000 dataloggers. Not all options are available for the CR5000 and CR295(X) dataloggers. There are four program instructions directly related to the TX320 GOES transmitter: **GoesData**, **GoesStatus**, **GoesGPS** and **GoesSetup**.

7.5.1 GoesData()

The **GoesData()** instruction is used to send data from the datalogger to the TX320 transmitter. Each time **GoesData()** is executed, data is ordered with the newest data to be transmitted first, which is opposite of how Edlog dataloggers arrange data.

There are five parameters to the **GoesData()** instruction: *Result Code*, *Data Table*, *Table Option*, *Buffer Control*, and *Data Format*.

In **GoesData()**, *Table Option*, *Buffer Control*, and *Data Format* can be variables declared as type long. Error checking is done at run time instead of compile time. See Section 8.2, *Result Codes* (p. 33), for runtime error codes and their descriptions.

Using CRBasic dataloggers, time of maximum, minimum, etc. are stored as number of seconds since 1990, which does not work for GOES transmission.

7.5.1.1 Result Code

The *Result Code* is used to determine if the **GoesData()** instruction executed successfully. When successful, **GoesData()** will return a zero to the *Result Code* variable. When **GoesData()** executes successfully, but there is no new data in the specified table, the *Result Code* is set to 100. See Section 8.2, *Result Codes* (p. 33), for details regarding result codes.

7.5.1.2 Data Table

The *Data Table* argument is used to specify which data table the **GoesData()** instruction is to copy data from.

7.5.1.3 Table Option

The *Table Option* is used to specify what data is copied from the data table. There are three options. Use 0 to specify all new data. Use 1 to specify only the most current record. Use any other positive number to specify the number of records to be copied each time **GoesData()** is executed. When copying data,

the entire record, except the timestamp and record number, is copied from the datalogger to the TX320 transmitter.

7.5.1.4 Buffer Control

Buffer Control is used to determine which buffer data is copied to, and if the buffer is erased before data is copied to the buffer. Use 0 to append to the self-timed buffer; use 1 to overwrite the self-timed buffer. Use 2 to append to the random buffer, and 3 to overwrite the random buffer.

7.5.1.5 Data Format

Data Format is used to determine what format the data is transmitted in. This is the format of the data sent over the satellite. The TX320 does not determine the actual data format used, but can be set to match for data format selected with this instruction. Use 0 for CSI floating point pseudo binary. Use 1 for floating point ASCII. Use 2 for 18-bit signed integer pseudo binary. Options 3 through 8 are used for RAWS7 or Fire Weather applications. Option 9 is used to clear the random buffer.

In dataloggers that support strings as a data type, all data format options except 3 (RAWS7) will support strings. Strings are transmitted from the first character until the null terminator. If strings contain illegal characters, the TX320 will replace the character with another character. By default the replacement character is an asterisk. The replacement character can be changed.

NOTE

Both the random and timed buffers of the TX320 can be set to accept ASCII or pseudo binary data. If the TX320 is set to pseudo binary, all ASCII data is transmitted as the replacement character, which is an asterisk by default. When the TX320 is set to ASCII data, both pseudo binary and ASCII data are transmitted normally. Data format options 0 and 2 are pseudo binary, all others are ASCII.

NOTE

When transmitting random messages in pseudo binary format the message counter must be turned off (RMC=N). The message count is a simple three digit count of how many times the transmission has been repeated. Digits 0 to 9 are not legal characters in pseudo binary mode and are replaced at transmission time with the replacement character specified by the IRC command. The default IRC character is *. If the random message counter is on when the random data format is set to pseudo binary, the first three characters sent are 0x20,0x20,0x2a (space,space,*) instead of the intended 0x20,0x20,0x31 (space,space,1).

NOTE

The order data appears in each transmission can be controlled. Only whole records are copied from the datalogger to the TX320. Each record is copied in the same order it appears in the datalogger memory. The order of data records, oldest to newest or newest to oldest, can be controlled. To arrange data records oldest to newest, execute the **GoesData()** instruction when data is written to the data table. To arrange data newest to oldest, execute the **GoesData()** instruction once per timed transmission. Either method works best when the table option is set to 0.

7.5.1.6 GOESData() Example**CRBasic Example 7-1. GOESData()**

```
' GOESData() Example
' Sample program makes a few simple measurements and
' stores the result in the table named Tempdata.
' All new data from TempData is copied to the
' transmitter hourly.

' An hourly record containing stats regarding
' the Last GOES message are stored in another table

'declarations
Public TCTemp
Public PanelT
Public battery1
Public RC_Data
Public LastStatus(14)

Alias LastStatus(1)=RC_Last
Alias LastStatus(2)=Lst_Type
Alias LastStatus(3)=Lst_Bytes
Alias LastStatus(4)=Lst_Forward
Alias LastStatus(5)=Lst_Reflected
Alias LastStatus(6)=Lst_BattVolt
Alias LastStatus(7)=Lst_GPS
Alias LastStatus(8)=Lst_OscDrift
Alias LastStatus(9)=Lat_Deg
Alias LastStatus(10)=Lat_Min
Alias LastStatus(11)=Lat_Secd
Alias LastStatus(12)=Long_Deg
Alias LastStatus(13)=Long_Min
Alias LastStatus(14)=Long_Secd

'program table
DataTable (Tempdata,1,1000)
  DataInterval (0,15,min,10)
  Sample (1,TCTemp,FP2)
  Sample (1,PanelT,FP2)
  Sample (1,battery1,FP2)
EndTable

DataTable(GoesStats,true,300)
DataInterval(0,1,hr,0)
Sample(14,LastStatus(),fp2)
EndTable

BeginProg
Scan (10,Sec,3,0)
  Battery (battery1)
  PanelTemp (PanelT,250)
  TCDiff (TCTemp,1,mV25C ,2,TypeT,PanelT,True ,0,250,1.8,32)
```

```

CallTable TempData
If IfTime (0,1,Hr)
    GOESData (RC_Data, TempData, 0, 0, 1)
EndIf
If IfTime (0,10,min)
    GOESStatus (LastStatus(), 2)
EndIf
CallTable GoesStats
NextScan
EndProg

```

7.5.2 GoesStatus()

The **GoesStatus()** instruction is used to read information from the TX320. Information that can be read and stored in the datalogger includes information relating to the next transmission, the last transmission, GPS time and position, and all logged errors. The status information can be used to set the datalogger clock and troubleshoot any problems that might arise. The **GoesStatus()** instruction also includes options to initiate a random transmission on command.

The **GoesStatus()** instruction includes seven different functions: *Read Time*, *Read Status*, *Read Last Message Status*, *Transmit Random Message*, *Read Error Register*, *Clear Error Register*, *Return Transmitter to Online Mode*.

GoesStatus() expects two parameters. The first is the array used to store the data returned by **GoesStatus()**; the second is the command to be issued. The first element of each array returned by the **GoesStatus()** command is the result code. The result code is used to test if the **GoesStatus()** instruction executed successfully. When the result code is zero, **GoesStatus()** executed successfully.

7.5.2.1 GoesStatus Read Time

Example:

```
Public gps(4)
```

```
GoesStatus(gps(), 0)
```

Command 0 (Read Time) will read the TX320 clock. Under normal operating conditions, the time is GMT. There are delays in reading the time from the TX320. The array needs to be four elements or more. Data are returned as: result code, hour, minute, second.

TABLE 7-1. GoesStatus Command 0: Read Time

Index	Contents
1	Command Result Code
2	Hours (GMT)
3	Minutes
4	Seconds

7.5.2.2 GoesStatus Read Status

Example:

```
Public Stats(13)
```

```
GoesStatus(Stats(), 1)
```

Command 1 (Read Status) is used to read information regarding the current status of the transmitter. Information returned includes the number of bytes in each data buffer, the time until transmission, and a loaded battery voltage.

Index	Contents
1	Command Result Code
2	Bytes of data in self-timed buffer
3	Time until next self-timed transmission: Days
4	Time until next self-timed transmission: Hours
5	Time until next self-timed transmission: Minutes
6	Time until next self-timed transmission: Seconds
7	Bytes of data in random buffer
8	Time until next random transmission interval start: Hours
9	Time until next random transmission interval start: Minutes
10	Time until next random transmission interval: Seconds
11	Fail-safe, 1 indicates transmitter disabled due to fail-safe.
12	Loaded power supply voltage, 1 amp load. (tenths of volts)
13	Average GPS acquisition time (tens of seconds)

7.5.2.3 GoesStatus Read Last Message Status

Example:

```
Public LastStats(14)
```

```
GoesStatus>LastStats(), 2)
```

Command 2 (Read Last Message Status) is used to read information regarding the last transmission. Information includes the type of transmission, size, forward power, reflected power, etc. Also returned is the GPS derived Latitude and Longitude, which is updated once a day. The GPS update interval can be changed.

Index	Contents
1	Command Result Code
2	Message type: Self-timed or Random
3	Size of message in bytes
4	Forward power in tenths of watts
5	Reflected power in tenths of watts
6	Power supply voltage under full load, in tenths of volts
7	GPS acquisition time in tens of seconds
8	Oscillator drift (signed, hundreds of Hz)
9	Latitude degrees
10	Latitude minutes
11	Latitude seconds
12	Longitude degrees
13	Longitude minutes
14	Longitude seconds

7.5.2.4 GoesStatus Read Error Register

Example:

```
Public Errors(10)
```

```
GoesStatus(Errors(), 4)
```

Command 4 (Read Error Register) is used to return the total number of errors that have occurred, and codes describing the last four errors. When the command that caused the error is listed as 31, the error is an internal fault. Otherwise the error is just a communication error.

Index	Contents
1	Result Code
2	Number of Errors
3	Command that Caused the Error
4	Error Code
5	Command that Caused the Error
6	Error Code
7	Command that Caused the Error
8	Error Code
9	Command that Caused the Error
10	Error Code

See Section 8.3, *Error Codes* (p. 35), for a list of error codes and details about the error codes.

7.5.3 GoesGPS

Example:

```
Public GPSdata(6), GPStime(7)
GoesGPS(GPSdata(), GPStime())
```

The instruction **GoesGPS()** returns two arrays of information. The first array is six elements long. The second array is seven elements long. The first array includes the result code (see TABLE 8-1), time in seconds since January 1, 2000, latitude in fractional degrees with 100 nanodegree resolution, longitude in fractional degrees with 100 nanodegree resolution, elevation as a signed 32-bit number in centimeters, and magnetic variation in fractional degrees with a one millidegree resolution.

The second array, which must be dimensioned to seven, holds year, month, day, hour (GMT), minute, seconds, microseconds. The second array can be used to set the datalogger's clock. See the **ClockSet()** instruction in the CRBasic help for details.

7.5.4 GoesSetup

In **GoesSetup()**, all parameters can be variables of type long except for the *Timed Interval*, *Timed Offset*, and *Random Interval* which are all of type string.

The **GoesSetup()** and **GoesData()** only return error messages at run time.

Using **GoesSetup()**, the datalogger can configure the transmitter under program control. Because the parameters in the **GoesSetup()** instruction can be variables, error checking is done at run time, not compile time. Using **GoesSetup()**, the custom display menu options, and the datalogger keypad/display, programs can be written to allow TX320 configuration via simple menus on the keypad/display. See CRBasic help and Display Menu for details. **GoesSetup()** can also be used with constant values allowing fixed GOES configuration parameters to be stored in the datalogger, and executed when needed.

After **GoesSetup()** executes, several TX320 settings are set to default values.

- 1) Messages are not centered in the transmission window.
- 2) Self-Timed message format is set to ASCII, which ONLY changes the flag word. Pseudo binary formats will still work.
- 3) Random message format is set to ASCII, which ONLY changes the flag word. Pseudo binary formats will still work.
- 4) Empty buffer message is turned off.
- 5) Randomizing percentage is set to 50%.
- 6) Data in the random buffer is repeated until cleared by the datalogger.
- 7) Random message counter is turned off.

Instruction details:

GoesSetup(*Result Code, Platform ID, Window, Timed Channel, Time Baud, Random Channel, Random Baud, Timed Interval, Timed Offset, Random Interval*)

7.5.4.1 Result Code

Result Code is used to indicate success or failure. Zero indicates success. Positive result codes indicate communication problems; negative result codes indicate an illegal value in one of the parameters. Refer to Section 8.2, *Result Codes* (p. 33), for error code tables and further details.

7.5.4.2 Platform ID

Platform ID is an eight-character hexadecimal number assigned by NESDIS. The *Platform ID* is always divisible by two. Valid characters are 0 to 9 and A to F.

7.5.4.3 Window

Window is the message window length in seconds. Valid range is 5 to 120.

7.5.4.4 Timed Channel

Timed Channel is the assigned self-timed transmission channel. Valid range for 300 bps is 0 to 266 and 0 to 133 for 1200 bps. Often, 1200 bps channels are referred to using the 300 channel number scheme. Divide by two to get the real 1200 baud channel number.

7.5.4.5 Timed Baud Rate

Timed Baud Rate is assigned and channel dependent. The assigned value for a CS2-compliant transmitter is either 300 or 1200.

7.5.4.6 Random Channel

Random Channel is the assigned random channel number. See *Timed Channel* description for valid entries.

7.5.4.7 Random Baud Rate

Random Baud Rate is assigned and channel dependent. The assigned value for a CS2-compliant device is either 300 or 1200.

7.5.4.8 Timed Interval

Timed Interval is assigned by NESDIS and is a string variable in the format of “dd_hh_mm_ss”, where dd is days and usually 00, hh is hours and usually 01, mm is minutes and usually 00, and ss is seconds and usually 00.

7.5.4.9 Timed Offset

Timed Offset is assigned by NESDIS and is a string variable in the format of “hh_mm_ss”, where hh is hours and usually 00, mm is minutes, and ss is seconds.

7.5.4.10 Random Offset

Random Offset is a string variable in the format of "hh_mm_ss" where hh and ss are usually zero and mm is 30 or 45.

7.5.4.11 GOESSetup() Example

CRBasic Example 7-2. GOESSetup()

```
Public setup_RC, setup

Sub Gsetup
  GOESSetup (setup_RC,&H12345677,10,195,300,0,100,"0_01_00_0" ,"0_16_20" ,"1_0_0" )
  If setup_RC = 0 Then setup = false
EndSub

BeginProg
  setup = true
  Scan (10,Sec,0,0)
  If setup Then Call Gsetup
  NextScan
EndProg
```

7.6 Edlog Programming

This section only applies to the CR10(X), CR23X, and CR510 dataloggers.

The datalogger is used to measure and record data values. The TX320 is used to transmit data over a GOES satellite to a ground receiving station. Program Instruction 126 is used to send data from the datalogger to the TX320 satellite transmitter. The TX320 has two data buffers. The data buffers will hold data until it is time to transmit the data. Data in the self-timed buffer is erased after transmission. Data in the random buffer will be erased after the preset number of repetitions has been met. When properly configured, the TX320 will ensure the data is transmitted on the correct channel, at the correct baud rate and at the correct time without overrunning the transmit window.

The datalogger will interface with the TX320 under program control. Two program instructions are used, **P126** and **P127**. **P126** is used to send data to a buffer. New data is either added to existing data (append) or overwrites existing data. In overwrite mode, all data in the buffer is erased before new data is written. **P127** is used to retrieve information from the TX320. Information regarding GPS time, latitude and longitude can be retrieved and stored in the datalogger. Information regarding the status and past errors can also be retrieved.

Data that is sent to the self-timed buffer 60 seconds or more before transmit time will be transmitted on the next scheduled transmission; otherwise, the data will be scheduled for a later transmission.

7.6.1 Deciding How Much Data will be Transmitted and When

The amount of data that can be transmitted depends on several factors: the transmit window length, the transmit baud rate, and the data format. The transmit window limits the time available for data to be sent. The baud rate determines how fast data is sent. The data format determines how many bytes are required per data point.

The maximum number of data points that can be sent is estimated with this formula:

$$b(a-2)/8c = \text{total number of data points per transmission}$$

Where:

a = window length in seconds

b = baud rate or bits/second; for example, 100, 300, or 1200

c = bytes per data point

Binary data uses 3 bytes per data point.

ASCII data uses 7 bytes per data point.

7.6.2 Deciding What Data Format to Use

The choice of data format effects two areas. First, the data format effects how much data can be sent in a single transmission. Binary data formats require 3 bytes per data point. ASCII data formats require 7 bytes per data point. Second, binary data must be decoded after transmission, ASCII does not. The datalogger formats the data before the data is sent to the TX320. The data format is chosen with the **P126** program instruction.

7.6.3 Managing Data, Writing More Data than Will Be Transmitted

The datalogger has two data storage areas: Final Storage area 1 (FS1) and Final Storage area 2 (FS2). When data is written to final storage, data is written to the active final storage area. The active final storage area defaults to FS1 when the datalogger starts the program table. Program Instruction 80 (**P80**) is used to set the active final storage area. When **P126** executes, all new data in the active final storage area is sent to the transmitter. New data is all data that has been written to the active final storage area since **P126** last executed.

Two separate data files can be maintained by managing which final storage area is active when data is written. The amount of data copied to the transmitter and the order of data copied to the transmitter can be controlled by utilizing both final storage areas. If using FS2, datalogger memory must be allocated to FS2. Final storage area 2 memory can be allocated using Edlog or the keypad.

7.6.4 Sending Data to the Transmitter (P126)

Edlog Instruction 126 is used to transfer data to the TX320.

1: Data Transfer to TX320 (P126)	
1: 0000	Buffer Control
2: 0000	Data Format
3: 0000	Result Code Loc [_____]

Parameter1: Buffer Control

0	Append to Self-Timed Buffer
1	Overwrite Self-Timed Buffer
2	Append to Random Buffer
3	Overwrite Random Buffer
9	Clear Random Buffer

Parameter 2: Data Format

0	CSI Floating Point Binary
1	Floating Point ASCII
2	Binary Integer, 18-bit
3	RAWS 7, Fire Weather
4	Fixed Decimal, ASCII, xxx.x
5	Fixed Decimal, ASCII, xx.xx
6	Fixed Decimal, ASCII, x.xxx
7	Fixed Decimal, ASCII, xxx
8	Fixed Decimal, ASCII, xxxxx

Parameter 3: Input Location for Result Code

1	Input Loc [_____]
---	---------------------

7.6.4.1 Buffer Control

The first parameter of Edlog Instruction 126 (**P126**) is called buffer control. Buffer control has two purposes: 1) to determine which buffer data is written to, and 2) if the buffer is erased before data is written. The TX320 has two independent buffers, one for self-timed transmissions and one for random transmissions. The self-timed buffer is treated differently than the random buffer. After a self-timed transmission, the data is erased from the self-timed buffer. After a random transmission, the data in the random buffer is scheduled to be transmitted again. Random transmissions are repeated at random intervals until **P126** is used to “Clear Random Buffer” or the random transmission repeat count has been met. The random buffer repeat count is set in the *Device Configuration Utility Settings Editor* | **Configuration**. Default is zero, which specifies that random transmission will occur on the interval until the random buffer is cleared by the host.

7.6.4.2 Data Format

The second parameter of **P126** is used to format the data. The data is formatted as **P126** copies data from the datalogger to the transmitter.

CSI floating point binary data requires 3 B per data point. Data must be low resolution. Sign and decimal location are maintained. This is an efficient data format.

Floating point ASCII requires 7 B per data point. Data must be low resolution. Sign and decimal location are maintained. Data does not need to be converted after transmission. Data points are separated by a comma. This is not an efficient data format, but it is convenient.

Binary, 18-bit, integer data format requires 3 B per data point. All data stored in the datalogger must be in high resolution. All information right of the decimal place is truncated. Data is transmitted as a signed, two’s compliment, 18-bit integer. Precision can be maintained by pre and post processing. This is an efficient data format that requires conversion and post processing. See Appendix D, *GOES DCS Transmit Frequencies (p. D-1)*, for details.

7.6.4.3 P126 Result Codes

The result codes can be used to increase the success rate of data transmissions. When the result code is 0, all went well. When the result code is 2 through 6,

P126 did not execute properly, but can still send the data. A result code of 7 indicates **P126** did not execute properly and the data probably cannot be sent again. Refer to Section 8.2, *Result Codes* (p. 33), for more information.

7.6.5 Read Status and Diagnostic Information from the TX320

Edlog Instruction 127 (**P127**) is used to read status and diagnostic information from the TX320.

1: TX320 Status (P127)	
1: 0000	Status Command
2: 0000	Result Code Loc [_____]

Parameter 1: Status Command

- 0 Read Time, Uses four Input Locations
- 1 Read Status, Uses 13 Input Locations
- 2 Read Last Message Status, Uses 14 Input Locations
- 3 Transmit Random Message, must be followed by command 6. One Input Location
- 4 Read Error Register, Uses Ten Input Locations
- 5 Reset Error Register, One Input Location
- 6 Return transmitter to online mode, used after command 3, One Input Location

Edlog Instruction 127 (**P127**) has four basic functions:

- 1) Datalogger will retrieve information from the TX320 transmitter.
- 2) Datalogger will initiate a test transmission on a random channel.
- 3) Datalogger will reset the error register of the TX320.
- 4) Return TX320 to online mode following a forced random transmission.

Parameter 1 allows you to determine what command will be issued to the TX320.

Parameter 2 is the starting input location for the string of information the TX320 will return.

Each **P127** command returns a string of information. Each command requires a different number of input locations. The first piece of information returned is always the result code of the command. TABLE 7-5 lists the result codes and explains them.

0	Execution successful
1	Checksum error in response
2	Time out waiting for STX character after addressing
3	Something besides STX received after addressing
4	Received a NAK
5	Timed out while waiting for an ACK
6	CS I/O not available
7	Transmit random message failure, could be no data in random buffer
9	Invalid command code

7.6.5.1 P127, Command 0: Read Time

Retrieve the GPS time from the transmitter. The time is Greenwich Mean Time (GMT). A time of 153 hours, 153 minutes, 153 seconds indicates GPS time is not available.

In Loc	Contents
1	Command Result Code
2	Hours (GMT)
3	Minutes
4	Seconds

7.6.5.2 P127, Command 1: Read Status

Read Status Command provides information specific to the next scheduled or random transmission, including the amount of data in the buffers and power supply voltage.

In Loc	Contents
1	Command Result Code
2	Bytes of data in self-timed buffer
3	Time until next self-timed transmission: Days
4	Time until next self-timed transmission: Hours
5	Time until next self-timed transmission: Minutes
6	Time until next self-timed transmission: Seconds
7	Bytes of data in random buffer
8	Time until next random transmission interval start: Hours
9	Time until next random transmission interval start: Minutes
10	Time until next random transmission interval: Seconds
11	Fail-safe, 1 indicates transmitter disabled due to fail-safe
12	Loaded power supply voltage, 1 amp load (tenths of volts)
13	Average GPS acquisition time (tens of seconds)

7.6.5.3 P127, Command 2: Read Last Message Status

Returns information specific to the last message transmitted plus the GPS derived Latitude and Longitude.

In Loc	Contents
1	Command Result Code
2	Message type: Self-timed or Random
3	Size of message in bytes
4	Forward power in tenths of watts
5	Reflected power in tenths of watts
6	Power supply voltage under full load, in tenths of volts
7	GPS acquisition time in tens of seconds
8	Oscillator drift (signed, hundreds of Hz)
9	Latitude degrees
10	Latitude minutes
11	Latitude seconds
12	Longitude degrees
13	Longitude minutes
14	Longitude seconds

7.6.5.4 P127, Command 3: Transmit Random Message

Overwrite random buffer with 1 2 3 4 (ASCII)

During GPS acquisition, the LED lights green.

During transmission, the LED lights red.

In Loc	Contents
1	Result Code

Random message channel and repeat interval must be enabled in the TX320 configuration. If random messages have not been enabled, command 3 will fail. If the GPS acquisition fails, the random transmission will fail. Command 3 will pull the TX320 offline. After the random transmission attempt, the TX320 must be put back on line with command 6. When command 6 is used, all data in the TX320 is erased. Random transmission may require up to five minutes (GPS timeout) for setup and transmission. If command 6 is executed before transmission, random transmission will be canceled.

During GPS acquisition, the LED will light solid green. During transmission, the LED will light solid red. Command 3 will return 1 value, the command result code. Zero indicates a successful execution of command 3, but does not indicate the random transmission has happened or was successful.

7.6.5.5 P127, Command 4: Read TX320 Error Registers

Read error registers of TX320. Requires 10 input locations.

In Loc	Contents
1	Result Code
2	Number of Errors
3	Command that Caused the Error
4	Error Code
5	Command that Caused the Error
6	Error Code
7	Command that Caused the Error
8	Error Code
9	Command that Caused the Error
10	Error Code

See Section 8.3, *Error Codes* (p. 35), for error code table and more information.

7.6.5.6 P127, Command 5: Clear TX320 Error Registers

Clear error registers of TX320. Requires one input location.

In Loc	Contents
1	Result Code

Result code of 0 indicates success. Command 5 is used to erase all errors from the error registers of the TX320.

7.6.5.7 P127, Command 6: Return TX320 to Online Mode

Command 6 is used to return the TX320 to online mode. Typically used after a forced random transmission. The TX320 has an offline time-out of one hour.

In Loc	Contents
1	Result code

Result code of 0 indicates success.

7.6.6 Edlog Programming Examples

Edlog Instruction 126 is used to copy data from the datalogger final storage area to the TX320 data buffer.

Edlog program example 1 writes data to final storage once an hour and transfers data to the TX320 once every 4 hours.

```

; Edlog Program Example 1

; Set output flag high hourly

1: If time is (P92)
  1: 0           Minutes (Seconds --) into a
  2: 60          Interval (same units as above)
  3: 10          Set Output Flag High (Flag 0)

; Write a time stamp to final storage

2: Real Time (P77)
  1: 1221        Year,Day,Hour/Minute,Seconds (midnight = 2400)

; Write 41 input locations to final storage

3: Sample (P70)
  1: 41          Reps
  2: 1           Loc [ Status_RC ]

; Check if top of 4 hour interval, if true execute P126

4: If time is (P92)
  1: 0           Minutes (Seconds --) into a
  2: 240         Interval (same units as above)
  3: 30          Then Do

; Transfer data to TX320

5: Data Transfer to HDR GOES (P126)
  1: 0           Self-Timed/Append
  2: 0           Binary Format
  3: 41          Result Code Loc [ P126_RC ]

6: End (P95)

```

8. Troubleshooting/Diagnostics

8.1 Diagnostics Button

The **DIAGNOSTICS** button has two purposes. Press and hold the **DIAGNOSTICS** button for about 2 seconds. The **STATUS** LED will flash once to indicate the fail-safe has not been tripped. If the LED flashes twice, the fail-safe has tripped. To clear the fail-safe, press and hold the **DIAGNOSTICS** button for about 10 seconds.

The fail-safe circuit is designed to shut down a malfunctioning transmitter that is transmitting too long or too often. The fail-safe circuit helps prevent malfunctioning transmitters from interfering with other transmissions.

8.2 Result Codes

Result code parameters are included in CRBasic's **GoesData()** and **GoesSetup()** instructions and in Edlog's Instruction 126. The *result codes* indicate whether the instruction executed successfully. When successful, a zero

will be stored in the variable or input location. A positive result code indicates a communication problem (see TABLE 8-1).

To better understand the communication result codes, it is necessary to understand the sequence of communication with the transmitter. Here are the steps:

- 1) The datalogger CS I/O port is checked to see if the serial port is available. If not, return code is 6.
- 2) The transmitter is addressed and should return the STX character within 200 ms. If there is no response from the transmitter, result code 2 is returned. If something other than the STX character is received, result code is 3.
- 3) The command to select a data buffer is sent (random or self-timed). The transmitter should respond with the ACK (06) character. If something besides the ACK is received, result code is 4. If nothing is received within 500 ms, result code is 5.
- 4) If the first three steps are successful, the datalogger sends the command to append or overwrite the data buffer, followed by the data. If the transmitter does not respond with the ACK character within 500 ms after the data has been transferred, the result code is 7. Result code 7 indicates the data was not received by the transmitter. The datalogger cannot resend the data.

The **GoesData()** and **GoesSetup()** instructions may also have a negative result code (see TABLE 8-2). A negative result code indicates that there is an illegal value in one of the parameters.

TABLE 8-1. Result Codes Indicating Communication Problems	
0	Command executed successfully
2	Time out waiting for STX character after SDC addressing
3	Wrong character (not STX) received after SDC Addressing
4	Something other than ACK returned when select data buffer command executed
5	Timed out waiting for an ACK when data buffer command was sent
6	CS I/O port not available, port busy
7	ACK not returned following data append or insert command

TABLE 8-2. GoesSetup and GoesData Runtime Result Codes

Code	Error Condition
-11	Illegal Buffer Control
-12	Illegal Message Window
-13	Illegal Channel Number
-14	Illegal Baud Rate
-15	R count Error
-16	Illegal Data Format
-17	Illegal Data Format FP2_ASCII
-18	Self-Timed Interval Error
-19	Self-Timed Offset Error
-20	Random Interval Error
-21	Platform ID Error

8.3 Error Codes

Error codes are stored in variables or input locations by using command 4 in CRBasic's **GoesStatus()** instruction or Edlog's Instruction 127 (see Section 7.5.2, *GoesStatus()* (p. 21), and Section 7.6.5, *Read Status and Diagnostic Information from the TX320* (p. 29)). TABLE 8-3 lists the possible error codes.

TABLE 8-3. Error Codes

Error Codes:	
Decimal	
00	No error
01	Illegal command
02	Command rejected
03	Illegal checksum or too much data
04	Time out or too little data
05	Illegal parameter
06	Transmit buffer overflow
16	PLL lock fault
17	GPS fix fault
18	Input power supply fault
19	Software fault
20	Fail-safe fault
21	GPS time synchronization fault
22	SWR fault – RF Load
23	Time Synch edge 1 detect fault
24	Time Synch edge 2 detect fault
25	Internal RF power supply failure

The TX320 has registers used to store information about errors that have occurred. The total number of errors is stored, up to 255. Also stored is the command that was issued when the error occurred and a code specific to the type or error.

Internal fault codes are stored. When the command that failed is listed as 31 (0x1F), the error condition is an internal error with the TX320. The datalogger receives the error code as a hex value and converts to decimal. Decimal values are placed in variables or input locations.

The error codes are very important information if the DCP experiences trouble during operation. Generally a GPS time synchronize fault should not cause concern, but a GPS fault may cause a scheduled transmission to be missed. The data will be sent on the next transmission if the instruction appends data to the self-timed buffer.

The internal TX320 errors provide critical information for diagnostics.

Error code 16 (0x10), message abort due to PLL, is a hardware failure of the phase locked loop circuit. Repeated PLL failures cannot be rectified in the field.

Error code 17 (0x11), message abort due to GPS, indicates the transmitter aborted a transmission because the required GPS information was not available at transmit time. Usually the transmitter will transmit on the next transmit time. Check GPS antenna placement and GPS antenna type. See Section 7.4, *GPS Antenna* (p. 17), for more information regarding the GPS antenna.

Error code 18 (0x12), message abort due to power supply, indicates the transmitter power supply did not provide enough voltage. Check system battery. If the system battery is low, the RF power supply will not be able to operate properly. *Device Configuration Utility* displays the supply voltage in **Settings Editor | Status** (see FIGURE 8-1). The loaded battery voltage must not drop below 10.8 volts.

Error code 19 (0x13), software error, indicates the transmitter was not able to run its internal software.

Error code 20 (0x14) is the fail-safe error. The fail-safe is an internal hardware circuit that will shut down the TX320 if it transmits too frequently or for too long. The fail-safe error code is not logged until the transmitter tries to transmit after the fail-safe has been tripped. The transmitter only trips the fail-safe when a serious hardware failure has occurred. Fail-safe limits are different for different baud rates. At 1200 bps, transmission cannot exceed 105 seconds or repeat more often than every 30 seconds. At 300 baud, transmission cannot exceed 270 seconds or repeat more often than every 30 seconds. The fail-safe can be reset by pressing and holding the reset switch for 10 seconds.

Error code 21 (0x15) indicates the transmitter missed a GPS fix, but does not guarantee a missed a transmission. Go to **Settings Editor | GPS** in *Device Configuration Utility* and ensure that the **GPS Fix Interval** setting does not coincide with the self-timed transmission interval. The GPS fix event must occur at least two minutes on either side of a self-timed transmission. Click the Apply button after making changes to the setting. See Section 7.4, *GPS Antenna* (p. 17), for additional GPS antenna information.

Error code 22 (0x16) indicates a Standing Wave Ratio (SWR) Fault. The SWR fault can be triggered by several different conditions. High reflected power will trigger the SWR fault. Reflected power is caused by poor transmission antenna and/or antenna cable condition or wrong type of antenna or antenna cable. See

Section 7, *Installation* (p. 15), for transmission antenna information. Ice buildup on an antenna can change the antenna properties, which can cause excessive reflected power. Corrosion in connectors, water in antenna cables, metal in close proximity to the antenna, and a damaged antenna can also cause excessive reflected power.

The SWR fault can also be triggered by a low battery. If the transmitter cannot generate enough transmission power, the SWR fault will trip. Always check the system battery if there has been an SWR fault. This condition is indicated by low reflected power.

To determine if the reflected power is too high or low, read the last message status information. When the reflected power number is divided by the forward power number, the result should be 0.5, with limits of 0.4 to 0.6. See Section 7.5.2.3, *GoesStatus Read Last Message Status* (p. 22), for details on the Last Message Status command.

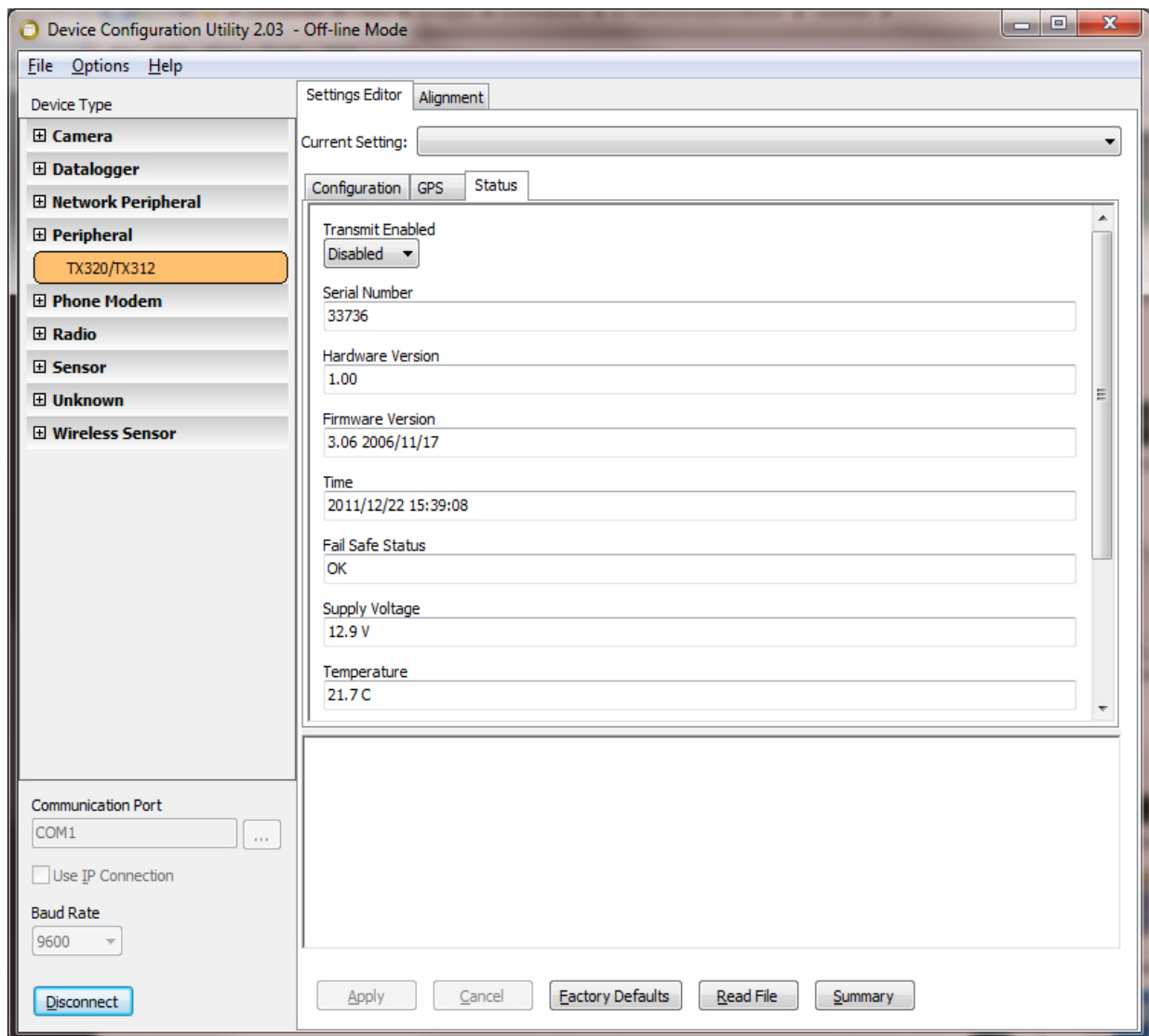

FIGURE 8-1. Settings Editor | Status in Device Configuration Utility

8.4 Using Device Configuration Utility for Troubleshooting/Testing

8.4.1 Setting Editor | GPS

This tab displays information about the GPS communication (see FIGURE 8-2). The GPS is required for proper operation. After the transmitter is reset, or first powered up, it can't schedule a transmission until a GPS fix has been established or the internal clock has been manually set.

If a GPS fix was missed, ensure that the GPS fix interval does not coincide with the self-timed transmission interval. A GPS Fix event must occur at least two minutes on either side of a self-timed transmission. Click **Apply** after changing the setting.

Also check the GPS antenna placement. Poor GPS antenna placement will increase the number of missed transmissions, or possibly stop all transmission (see Section 7.4, *GPS Antenna* (p. 17), for more information).

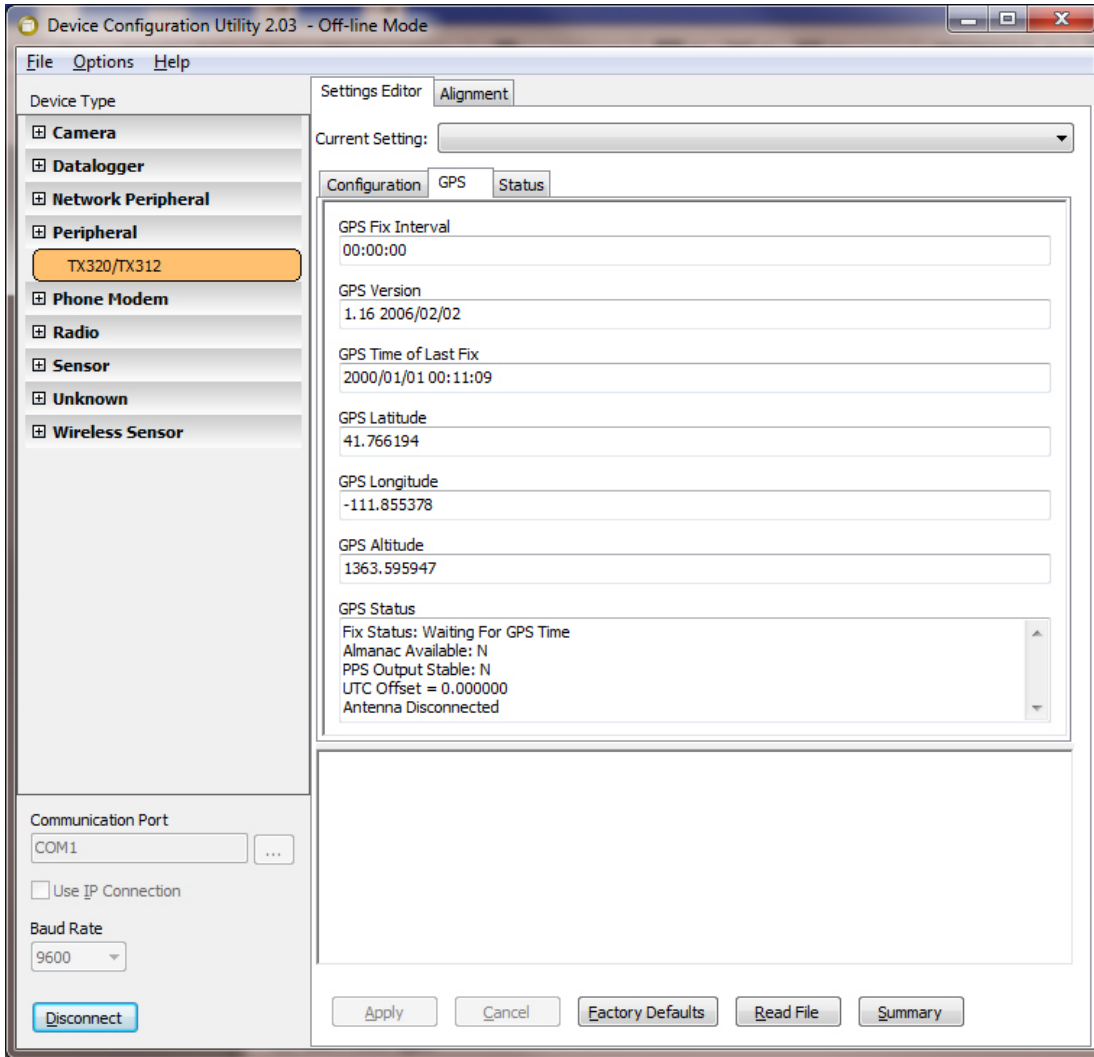

FIGURE 8-2. Settings Editor | GPS in Device Configuration Utility

8.4.2 Setting Editor | Status

The **Status** tab provides a lot of useful information about the transmitter that can help in troubleshooting (see FIGURE 8-1). Specifically, ensure that the fail-safe status is OK. Also the supply voltage amount needs to be greater than 10.8 V. Replace the battery if the supply voltage amount is too low.

8.4.3 Terminal

The **Terminal** tab supports manually-entered commands (see Appendix F, *Extended ASCII Command Set (p. F-1)*, for individual commands). It also includes buttons on the right side of the screen that provide the following functions.

Read Audit Log: Displays a history of the transmitter operation. The latest entry in the audit log is shown at the top of the screen. The audit log will record any error condition that has occurred in the past, plus other events.

Clear Timed Buffer: Erases all data from the self-timed buffer.

Clear Random Buffer: Erases all data from the random buffer.

Send to Timed Buffer: Send data to the self-timed buffer. Data will then be scheduled for transmission on the next available time slot.

Send to Random Buffer: Send data to the random buffer. Data will then be scheduled for transmission very soon.

Appendix A. Information on Eligibility and Getting Onto the GOES System

A.1 Eligibility

U.S. federal, state, or local government agencies, or users sponsored by one of those agencies, may use GOES. Potential GOES users must receive formal permission from NESDIS.

A.2 Acquiring Permission

1. The user contacts NESDIS at the following address and submits a formal request to transmit data via GOES. Non-U.S. or private users must also submit a written statement indicating that their sponsor requires all or part of the transmitted data. NESDIS will fax or mail the user a question form to complete and submit for approval.

DCS Coordinator
Federal Office Building 4
Suitland, MD
(301) 457-5681
<http://dcs.noaa.gov/contact.htm>

2. Following approval, NESDIS sends a Memorandum of Agreement (MOA). The MOA must be signed and returned to NESDIS.
3. After the MOA is approved, NESDIS will issue a channel assignment and an ID address code.
4. NESDIS MUST BE contacted to coordinate a “start-up” date.

See noaasis.noaa.gov/DCS for more information.

Appendix B. Data Conversion Computer Program (written in BASIC)

```
1  REM THIS PROGRAM CONVERTS 3-BYTE ASCII DATA INTO
    DECIMAL
5  INPUT "RECEIVE FILE?", RF$
6  OPEN RF$ FOR OUTPUT AS #2
10 INPUT "NAME OF FILE CONTAINING GOES DATA"; NFL$
20 DIM DV$(200)
25 WIDTH "LPT1:", 120
30 OPEN NFL$ FOR INPUT AS #1
40 WHILE NOT EOF(1)
50 LINE INPUT #1, A$
55 A$ = MID$(A$, 38)
56 PRINT A$
100 J = INT(LEN(A$) / 3)
105 PRINT J
110 FOR I = 1 TO J
120 DV$(I) = MID$(A$, 3 * I - 2, 3)
130 NEXT I
140 B$ = RIGHT$(A$, LEN(A$) - 3 * J)
160 A$ = B$ + A$
170 K = INT(LEN(A$) / 3)
180 L = J
190 FOR I = J + 1 TO L
200 DV$(I) = MID$(A$, 3 * (I - J) - 2, 3)
210 NEXT I
270 FOR I = 1 TO L
280 A = ASC(LEFT$(DV$(I), 1)) AND 15
290 B = ASC(MID$(DV$(I), 2, 1)) AND 63
300 C = ASC(RIGHT$(DV$(I), 1)) AND 63
310 IF (A * 64) + B >= 1008 THEN DV = (B - 48) * 64 + C + 9000:
    GOTO 400
320 IF A AND 8 THEN SF = -1 ELSE SF = 1
330 IF A AND 4 THEN SF = SF * .01
340 IF A AND 2 THEN SF = SF * .1
350 IF A AND 1 THEN DV = 4096
360 DV = (DV + ((B AND 63) * 64) + (C AND 63)) * SF
400 PRINT #2, USING "#####.### "; DV;
405 IF I MOD 17 = 0 THEN PRINT #2, CHR$(13)
406 DV = 0
410 NEXT I
1000 WEND
```

Appendix C. Antenna Orientation Computer Program (written in BASIC)

```
5  REM THIS PROGRAM CALCULATES THE AZIMUTH AND
    ELEVATION FOR AN
6  REM ANTENNA USED WITH A DCP FOR GOES SATELLITE
    COMMUNICATIONS
10  CLS : CLEAR 1000
20  INPUT "SATELLITE LONGITUDE (DDD.DD)"; SO
30  INPUT "ANTENNA LONGITUDE (DDD.DD)"; SA
40  PRINT "ANTENNA LATITUDE (DDD.DD)--(SOUTH LATITUDE
    ENTERED"
45  INPUT "AS NEGATIVE NUMBER)"; AA: A = 90 - AA
50  INPUT "ANTENNA HEIGHT ABOVE SEA LEVEL IN FEET"; AH
60  T = SO - SA: TR = T * .01745329#: BR = 90 * .01745329#: AR = A *
    .01745329#
70  X = COS(AR) * COS(BR) + SIN(AR) * SIN(BR) * COS(TR)
80  CR = -ATN(X / SQR(-X * X + 1)) + 1.5708
90  C = CR * (1 / .01745329#)
100 X1 = (SIN(BR) * SIN(TR)) / SIN(CR)
110 BR = ATN(X1 / SQR(-X1 * X1 + 1)): B = BR * (1 / .01745329#)
115  GOSUB 300
120  A1 = 90 - C: R1 = A1 * .01745329#
130  S1 = (6378 + (AH * .0003048)) / SIN(R1)
140  S2 = 357851 + 6378 - S1
150  A2 = 180 - A1: R2 = A2 * .01745329#
155  S4 = SQR(S1 ^ 2 - (6378 + AH * .0003048) ^ 2)
160  S3 = SQR(S4 ^ 2 + S2 ^ 2 - 2 * S4 * S2 * COS(R2))
170  X2 = (SIN(R2) / S3) * S2
180  ER = ATN(X2 / SQR(-X2 * X2 + 1)): E = ER * (1 / .01745329#)
190  PRINT "ANTENNA ELEVATION ANGLE="; E; " DEGREES"
200  PRINT "ANTENNA AZIMUTH ANGLE="; B; " DEGREES"
210  PRINT : PRINT : PRINT "HIT ANY KEY TO CONTINUE"
220  I$ = INKEY$: IF I$ = "" THEN 220 ELSE CLS : GOTO 20
300  IF T < 0 AND AA > 0 THEN B = B + 180: GOTO 380
310  IF T < 0 AND AA < 0 THEN B = B * -1: GOTO 380
320  IF T > 0 AND AA < 0 THEN B = 360 - B: GOTO 380
330  IF T > 0 AND AA > 0 THEN B = B + 180: GOTO 380
340  IF T = 0 AND AA > 0 THEN B = 180: GOTO 380
350  IF T = 0 AND AA < 0 THEN B = 360: GOTO 380
360  IF AA = 0 AND T > 0 THEN B = 270: GOTO 380
370  IF AA = 0 AND T < 0 THEN B = 90
380  RETURN
400  RETURN
460  RETURN
```

Appendix D. GOES DCS Transmit Frequencies

TABLE D-1. GOES DCPRS Transmit Frequencies Certification Standard 1.0

300 & 100 bps Channels		1200 bps Channels		300 & 100 bps Channels		1200 bps Channels	
Channel Number	Frequency MHz	Channel Number+ A	Frequency MHz	Channel Number	Frequency MHz	Channel Number+ A	Frequency MHz
1	401.701000	1	401.701750	46	401.768500		
2	401.702500			47	401.770000	24	401.770750
3	401.704000	2	401.704750	48	401.771500		
4	401.705500			49	401.773000	25	401.773750
5	401.707000	3	401.707750	50	401.774500		
6	401.708500			51	401.776000	26	401.776750
7	401.710000	4	401.710750	52	401.777500		
8	401.711500			53	401.779000	27	401.779750
9	401.713000	5	401.713750	54	401.780500		
10	401.714500			55	401.782000	28	401.782750
11	401.716000	6	401.716750	56	401.783500		
12	401.717500			57	401.785000	29	401.785750
13	401.719000	7	401.719750	58	401.786500		
14	401.720500			59	401.788000	30	401.788750
15	401.722000	8	401.722750	60	401.789500		
16	401.723500			61	401.791000	31	401.791750
17	401.725000	9	401.725750	62	401.792500		
18	401.726500			63	401.794000	32	401.794750
19	401.728000	10	401.728750	64	401.795500		
20	401.729500			65	401.797000	33	401.797750
21	401.731000	11	401.731750	66	401.798500		
22	401.732500			67	401.800000	34	401.800750
23	401.734000	12	401.734750	68	401.801500		
24	401.735500			69	401.803000	35	401.803750
25	401.737000	13	401.737750	70	401.804500		
26	401.738500			71	401.806000	36	401.806750
27	401.740000	14	401.740750	72	401.807500		
28	401.741500			73	401.809000	37	401.809750
29	401.743000	15	401.743750	74	401.810500		
30	401.744500			75	401.812000	38	401.812750
31	401.746000	16	401.746750	76	401.813500		
32	401.747500			77	401.815000	39	401.815750
33	401.749000	17	401.749750	78	401.816500		
34	401.750500			79	401.818000	40	401.818750
35	401.752000	18	401.752750	80	401.819500		
36	401.753500			81	401.821000	41	401.821750
37	401.755000	19	401.755750	82	401.822500		
38	401.756500			83	401.824000	42	401.824750
39	401.758000	20	401.758750	84	401.825500		
40	401.759500			85	401.827000	43	401.827750
41	401.761000	21	401.761750	86	401.828500		
42	401.762500			87	401.830000	44	401.830750
43	401.764000	22	401.764750	88	401.831500		
44	401.765500			89	401.833000	45	401.833750
45	401.767000	23	401.767750	90	401.834500		

TABLE D-1. GOES DCPRS Transmit Frequencies Certification Standard 1.0 (continued)								
300 & 100 bps Channels		1200 bps	Channels		300 & 100 bps Channels	1200 bps	Channels	
Channel	Frequency	Channel	Frequency		Channel	Frequency	Channel	
Number	MHz	Number+ A	MHz		Number	MHz	Number+ A	
91	401.836000	46	401.836750		141	401.911000	71	401.911750
92	401.837500				142	401.912500		
93	401.839000	47	401.839750		143	401.914000	72	401.914750
94	401.840500				144	401.915500		
95	401.842000	48	401.842750		145	401.917000	73	401.917750
96	401.843500				146	401.918500		
97	401.845000	49	401.845750		147	401.920000	74	401.920750
98	401.846500				148	401.921500		
99	401.848000	50	401.848750		149	401.923000	75	401.923750
100	401.849500				150	401.924500		
101	401.851000	51	401.851750		151	401.926000	76	401.926750
102	401.852500				152	401.927500		
103	401.854000	52	401.854750		153	401.929000	77	401.929750
104	401.855500				154	401.930500		
105	401.857000	53	401.857750		155	401.932000	78	401.932750
106	401.858500				156	401.933500		
107	401.860000	54	401.860750		157	401.935000	79	401.935750
108	401.861500				158	401.936500		
109	401.863000	55	401.863750		159	401.938000	80	401.938750
110	401.864500				160	401.939500		
111	401.866000	56	401.866750		161	401.941000	81	401.941750
112	401.867500				162	401.942500		
113	401.869000	57	401.869750		163	401.944000	82	401.944750
114	401.870500				164	401.945500		
115	401.872000	58	401.872750		165	401.947000	83	401.947750
116	401.873500				166	401.948500		
117	401.875000	59	401.875750		167	401.950000	84	401.950750
118	401.876500				168	401.951500		
119	401.878000	60	401.878750		169	401.953000	85	401.953750
120	401.879500				170	401.954500		
121	401.881000	61	401.881750		171	401.956000	86	401.956750
122	401.882500				172	401.957500		
123	401.884000	62	401.884750		173	401.959000	87	401.959750
124	401.885500				174	401.960500		
125	401.887000	63	401.887750		175	401.962000	88	401.962750
126	401.888500				176	401.963500		
127	401.890000	64	401.890750		177	401.965000	89	401.965750
128	401.891500				178	401.966500		
129	401.893000	65	401.893750		179	401.968000	90	401.968750
130	401.894500				180	401.969500		
131	401.896000	66	401.896750		181	401.971000	91	401.971750
132	401.897500				182	401.972500		
133	401.899000	67	401.899750		183	401.974000	92	401.974750
134	401.900500				184	401.975500		
135	401.902000	68	401.902750		185	401.977000	93	401.977750
136	401.903500				186	401.978500		
137	401.905000	69	401.905750		187	401.980000	94	401.980750
138	401.906500				188	401.981500		
139	401.908000	70	401.908750		189	401.983000	95	401.983750
140	401.909500				190	401.984500		

TABLE D-1. GOES DCPRS Transmit Frequencies Certification Standard 1.0 (continued)							
300 & 100 bps Channels		1200 bps Channels		300 & 100 bps Channels		1200 bps Channels	
Channel Number	Frequency MHz	Channel Number+ A	Frequency MHz	Channel Number	Frequency MHz	Channel Number+ A	Frequency MHz
191	401.986000	96	401.986750	241	402.061000	121	402.061750
192	401.987500			242	402.062500		
193	401.989000	97	401.989750	243	402.064000	122	402.064750
194	401.990500			244	402.065500		
195	401.992000	98	401.992750	245	402.067000	123	402.067750
196	401.993500			246	402.068500		
197	401.995000	99	401.995750	247	402.070000	124	402.070750
198	401.996500			248	402.071500		
199	401.998000	100	401.998750	249	402.073000	125	402.073750
200	401.999500			250	402.074500		
201	402.001000	101	402.001750	251	402.076000	126	402.076750
202	402.002500			252	402.077500		
203	402.004000	102	402.004750	253	402.079000	127	402.079750
204	402.005500			254	402.080500		
205	402.007000	103	402.007750	255	402.082000	128	402.082750
206	402.008500			256	402.083500		
207	402.010000	104	402.010750	257	402.085000	129	402.085750
208	402.011500			258	402.086500		
209	402.013000	105	402.013750	259	402.088000	130	402.088750
210	402.014500			260	402.089500		
211	402.016000	106	402.016750	261	402.091000	131	402.091750
212	402.017500			262	402.092500		
213	402.019000	107	402.019750	263	402.094000	132	402.094750
214	402.020500			264	402.095500		
215	402.022000	108	402.022750	265	402.097000	133	402.097750
216	402.023500			266	402.098500		
217	402.025000	109	402.025750				
218	402.026500						
219	402.028000	110	402.028750				
220	402.029500						
221	402.031000	111	402.031750				
222	402.032500						
223	402.034000	112	402.034750				
224	402.035500						
225	402.037000	113	402.037750				
226	402.038500						
227	402.040000	114	402.040750				
228	402.041500						
229	402.043000	115	402.043750				
230	402.044500						
231	402.046000	116	402.046750				
232	402.047500						
233	402.049000	117	402.049750				
234	402.050500						
235	402.052000	118	402.052750				
236	402.053500						
237	402.055000	119	402.055750				
238	402.056500						
239	402.058000	120	402.058750				
240	402.059500						

TABLE D-2. GOES DCPRS Transmit Frequencies Certification Standard 2.0					
Channel Number	Center Frequency	Channel Number	Center Frequency	Channel Number	Center Frequency
1	401.701000	323	401.734750	46	401.768500
301	401.701750	24	401.735500	346	401.769250
2	401.702500	324	401.736250	47	401.770000
302	401.703250	25	401.737000	347	401.770750
3	401.704000	325	401.737750	48	401.771500
303	401.704750	26	401.738500	348	401.772250
4	401.705500	326	401.739250	49	401.773000
304	401.706250	27	401.740000	349	401.773750
5	401.707000	327	401.740750	50	401.774500
305	401.707750	28	401.741500	350	401.775250
6	401.708500	328	401.742250	51	401.776000
306	401.709250	29	401.743000	351	401.776750
7	401.710000	329	401.743750	52	401.777500
307	401.710750	30	401.744500	352	401.778250
8	401.711500	330	401.745250	53	401.779000
308	401.712250	31	401.746000	353	401.779750
9	401.713000	331	401.746750	54	401.780500
309	401.713750	32	401.747500	354	401.781250
10	401.714500	332	401.748250	55	401.782000
310	401.715250	33	401.749000	355	401.782750
11	401.716000	333	401.749750	56	401.783500
311	401.716750	34	401.750500	356	401.784250
12	401.717500	334	401.751250	57	401.785000
312	401.718250	35	401.752000	357	401.785750
13	401.719000	335	401.752750	58	401.786500
313	401.719750	36	401.753500	358	401.787250
14	401.720500	336	401.754250	59	401.788000
314	401.721250	37	401.755000	359	401.788750
15	401.722000	337	401.755750	60	401.789500
315	401.722750	38	401.756500	360	401.790250
16	401.723500	338	401.757250	61	401.791000
316	401.724250	39	401.758000	361	401.791750
17	401.725000	339	401.758750	62	401.792500
317	401.725750	40	401.759500	362	401.793250
18	401.726500	340	401.760250	63	401.794000
318	401.727250	41	401.761000	363	401.794750
19	401.728000	341	401.761750	64	401.795500
319	401.728750	42	401.762500	364	401.796250
20	401.729500	342	401.763250	65	401.797000
320	401.730250	43	401.764000	365	401.797750
21	401.731000	343	401.764750	66	401.798500
321	401.731750	44	401.765500	366	401.799250
22	401.732500	344	401.766250	67	401.800000
322	401.733250	45	401.767000	367	401.800750
23	401.734000	345	401.767750	68	401.801500

NOTE: Bold type face identifies potential 1200 bps channel assignments.

TABLE D-2. GOES DCPRS Transmit Frequencies Certification Standard 2.0 (continued)					
Channel Number	Center Frequency	Channel Number	Center Frequency	Channel Number	Center Frequency
368	401.802250	91	401.836000	413	401.869750
69	401.803000	391	401.836750	114	401.870500
369	401.803750	92	401.837500	414	401.871250
70	401.804500	392	401.838250	115	401.872000
370	401.805250	93	401.839000	415	401.872750
71	401.806000	393	401.839750	116	401.873500
371	401.806750	94	401.840500	416	401.874250
72	401.807500	394	401.841250	117	401.875000
372	401.808250	95	401.842000	417	401.875750
73	401.809000	395	401.842750	118	401.876500
373	401.809750	96	401.843500	418	401.877250
74	401.810500	396	401.844250	119	401.878000
374	401.811250	97	401.845000	419	401.878750
75	401.812000	397	401.845750	120	401.879500
375	401.812750	98	401.846500	420	401.880250
76	401.813500	398	401.847250	121	401.881000
376	401.814250	99	401.848000	421	401.881750
77	401.815000	399	401.848750	122	401.882500
377	401.815750	100	401.849500	422	401.883250
78	401.816500	400	401.850250	123	401.884000
378	401.817250	101	401.851000	423	401.884750
79	401.818000	401	401.851750	124	401.885500
379	401.818750	102	401.852500	424	401.886250
80	401.819500	402	401.853250	125	401.887000
380	401.820250	103	401.854000	425	401.887750
81	401.821000	403	401.854750	126	401.888500
381	401.821750	104	401.855500	426	401.889250
82	401.822500	404	401.856250	127	401.890000
382	401.823250	105	401.857000	427	401.890750
83	401.824000	405	401.857750	128	401.891500
383	401.824750	106	401.858500	428	401.892250
84	401.825500	406	401.859250	129	401.893000
384	401.826250	107	401.860000	429	401.893750
85	401.827000	407	401.860750	130	401.894500
385	401.827750	108	401.861500	430	401.895250
86	401.828500	408	401.862250	131	401.896000
386	401.829250	109	401.863000	431	401.896750
87	401.830000	409	401.863750	132	401.897500
387	401.830750	110	401.864500	432	401.898250
88	401.831500	410	401.865250	133	401.899000
388	401.832250	111	401.866000	433	401.899750
89	401.833000	411	401.866750	134	401.900500
389	401.833750	112	401.867500	434	401.901250
90	401.834500	412	401.868250	135	401.902000
390	401.835250	113	401.869000	435	401.902750

NOTE: Bold type face identifies potential 1200 bps channel assignments.

TABLE D-2. GOES DCPRS Transmit Frequencies Certification Standard 2.0 (continued)					
Channel Number	Center Frequency	Channel Number	Center Frequency	Channel Number	Center Frequency
136	401.903500	458	401.937250	181	401.971000
436	401.904250	159	401.938000	481	401.971750
137	401.905000	459	401.938750	182	401.972500
437	401.905750	160	401.939500	482	401.973250
138	401.906500	460	401.940250	183	401.974000
438	401.907250	161	401.941000	483	401.974750
139	401.908000	461	401.941750	184	401.975500
439	401.908750	162	401.942500	484	401.976250
140	401.909500	462	401.943250	185	401.977000
440	401.910250	163	401.944000	485	401.977750
141	401.911000	463	401.944750	186	401.978500
441	401.911750	164	401.945500	486	401.979250
142	401.912500	464	401.946250	187	401.980000
442	401.913250	165	401.947000	487	401.980750
143	401.914000	465	401.947750	188	401.981500
443	401.914750	166	401.948500	488	401.982250
144	401.915500	466	401.949250	189	401.983000
444	401.916250	167	401.950000	489	401.983750
145	401.917000	467	401.950750	190	401.984500
445	401.917750	168	401.951500	490	401.985250
146	401.918500	468	401.952250	191	401.986000
446	401.919250	169	401.953000	491	401.986750
147	401.920000	469	401.953750	192	401.987500
447	401.920750	170	401.954500	492	401.988250
148	401.921500	470	401.955250	193	401.989000
448	401.922250	171	401.956000	493	401.989750
149	401.923000	471	401.956750	194	401.990500
449	401.923750	172	401.957500	494	401.991250
150	401.924500	472	401.958250	195	401.992000
450	401.925250	173	401.959000	595	401.992750
151	401.926000	473	401.959750	196	401.993500
451	401.926750	174	401.960500	496	401.994250
152	401.927500	474	401.961250	197	401.995000
452	401.928250	175	401.962000	497	401.995750
153	401.929000	475	401.962750	198	401.996500
453	401.929750	176	401.963500	498	401.997250
154	401.930500	476	401.964250	199	401.998000
454	401.931250	177	401.965000	499	401.998750
155	401.932000	477	401.965750	200	401.999500
455	401.932750	178	401.966500	500	402.000250
156	401.933500	478	401.967250	201	402.001000
456	401.934250	179	401.968000	501	402.001750
157	401.935000	479	401.968750	202	402.002500
457	401.935750	180	401.969500	502	402.003250
158	401.936500	480	401.970250	203	402.004000

NOTE: Bold type face identifies potential 1200 bps channel assignments.

TABLE D-2. GOES DCPRS Transmit Frequencies Certification Standard 2.0 (continued)					
Channel Number	Center Frequency	Channel Number	Center Frequency	Channel Number	Center Frequency
503	402.004750	226	402.038500	548	402.072250
204	402.005500	526	402.039250	249	402.073000
504	402.006250	227	402.040000	549	402.073750
205	402.007000	527	402.040750	250	402.074500
505	402.007750	228	402.041500	550	402.075250
206	402.008500	528	402.042250	251	402.076000
506	402.009250	229	402.043000	551	402.076750
207	402.010000	529	402.043750	252	402.077500
507	402.010750	230	402.044500	552	402.078250
208	402.011500	530	402.045250	253	402.079000
508	402.012250	231	402.046000	553	402.079750
209	402.013000	531	402.046750	254	402.080500
509	402.013750	232	402.047500	554	402.081250
210	402.014500	532	402.048250	255	402.082000
510	402.015250	233	402.049000	555	402.082750
211	402.016000	533	402.049750	256	402.083500
511	402.016750	234	402.050500	556	402.084250
212	402.017500	534	402.051250	257	402.085000
512	402.018250	235	402.052000	557	402.085750
213	402.019000	535	402.052750	258	402.086500
513	402.019750	236	402.053500	558	402.087250
214	402.020500	536	402.054250	259	402.088000
514	402.021250	237	402.055000	559	402.088750
215	402.022000	537	402.055750	260	402.089500
515	402.022750	238	402.056500	560	402.090250
216	402.023500	538	402.057250	261	402.091000
516	402.024250	239	402.058000	561	402.091750
217	402.025000	539	402.058750	262	402.092500
517	402.025750	240	402.059500	562	402.093250
218	402.026500	540	402.060250	263	402.094000
518	402.027250	241	402.061000	563	402.094750
219	402.028000	541	402.061750	264	402.095500
519	402.028750	242	402.062500	564	402.096250
220	402.029500	542	402.063250	265	402.097000
520	402.030250	243	402.064000	565	402.097750
221	402.031000	543	402.064750	266	402.098500
521	402.031750	244	402.065500	566	402.099250
222	402.032500	544	402.066250		
522	402.033250	245	402.067000		
223	402.034000	545	402.067750		
523	402.034750	246	402.068500		
224	402.035500	546	402.069250		
524	402.036250	247	402.070000		
225	402.037000	547	402.070750		
525	402.037750	248	402.071500		

NOTE: Bold type face identifies potential 1200 bps channel assignments.

Where the 18-bit data point is made by combining the three bytes after bit 7 and bit 6 of each byte have been dropped.
 Where 0 represents bit 0 - the least significant bit
 Where 17 represents bit 17 - the most significant bit and is used to determine the sign.

Converting the 18-bit data point to an integer can be done manually. Don't forget the 18-bits are numbered 0 through 17. Bit 17 is the sign bit, when bit 17 is set, the number is negative. If bit 17 is set, subtract 1 from the number then take the complement of the number. If bit 17 is not set, simply convert the number to its decimal equivalent.

Example positive data point conversion:

Byte Label	byte 3	byte 2	byte 1
Actual data point	01000101	11110010	11010010
Drop first 2 bits of each byte	000101	110010	010010
Combine the 3 bytes into one word	000101 110010 010010		
Convert from Binary to Decimal	23698		

Example of a negative data point conversion:

Byte Label	byte 3	byte 2	byte 1
Actual data point	01111010	11001101	11101101
Drop first 2 bits of each byte	111010	001101	101101
Notice bit 17 is set,			
Combine the 3 bytes into one word	111010 001101 101101		
Subtract 1 from the number	111010 001101 101100		
Take the complement of each bit	000101 110010 010011		
Convert the binary value into a decimal value, don't forget the negative sign	-23699		

Appendix F. Extended ASCII Command Set

Appendix F describes the ASCII command interface for the TX320 transmitter. These commands can be entered using the terminal window of the Device Configuration Utility, or suitable terminal emulation software.

F.1 Command Interface

F.1.1 Port Interfaces

All data entry and diagnostic functions are accessed using either the RS-232 Interface or USB interface.

F.1.1.1 RS-232 Details

The default settings for the RS-232 port are 9600 baud, 8 data bits, no parity and 1 stop bit.

Three RS-232 connections (TXD, RXD and GND) are used, no handshaking is needed and should be set to none in the terminal emulator.

F.1.1.2 Command Protocol

A [CR] (0x0d) must be entered to get the transmitter's attention and is used to terminate a command line. The transmitter responds with a '>' (0x3e) to indicate that it is ready to receive a command. If no characters are entered for 60 seconds, any partially entered commands are deleted and the transmitter's attention is lost. To get the transmitters attention, a character must be entered followed by a [CR] until the '>' prompt is returned.

Commands can optionally be terminated with [CR][LF]; in other words, a [LF] character received following a [CR] will be ignored.

Each character entered is echoed to the host to allow for simple error checking and to support the terminal nature of the implementation. A backspace character (BS, 0x08) deletes the last character entered. The ESC character (0x1b) will delete the entire command.

The command protocol is not case sensitive. Many commands are used to set or retrieve various configuration parameters. When setting parameters, the command is followed by an equals sign ('=') and a comma separated list of parameters. When retrieving parameters, the command is entered without the '=' or followed by a question mark ('?').

Some commands are used to direct the transmitter to execute a specific function (for example, clear a buffer); in such cases, neither a '=' or a '?' is required. If the command has parameters associated with it, they will appear as a comma separated list following the command itself.

Unless otherwise noted, the transmitter will respond to all commands with one of the following:

"OK[CR][LF]>" if command was accepted,
"Bad parameter[CR][LF]>" if a command parameter was invalid,
"Unknown Format[CR][LF]>" if there are too many or too few parameters,
"Access Denied![CR][LF]>" if the command requires a higher access level,
"Unknown Command[CR][LF]>" if the command is unknown,
"Execution Error[CR][LF]>" if the command fails during execution,
"Transmitter Must Be Disabled[CR][LF]>" if the transmitter must be disabled prior to using this command.,
"Transmitter Must Be Enabled[CR][LF]>" if command must first be enabled,
"Configuration Not Recognized[CR][LF]>" if configuration is invalid,

If the command was a request for a configuration parameter the transmitter will respond with:

<cmd>=<data>[CR][LF]> When returning data parameters.

F.1.1.3 Command Access Level

All commands are subject to an access right to restrict access to calibration and test commands. Two access levels are defined: USER and TECHNICIAN. An error will be returned if a TECHNICIAN level command is entered while at the USER command access level. USER level commands are always available including when at the TECHNICIAN command access level. The TECHNICIAN level commands are not described here.

The command access level is changed by using the password protected TECHMODE command. After power up the access level is always USER. The access level of each command is noted in each command description.

Some commands are only available when transmissions are disabled. This is also noted along with each command description.

F.2 General Configuration Commands

F.2.1 Clock Read/Set

Syntax:

TIME= yyyy/mm/dd hh:mm:ss

Access level: USER

TX320 State: Enabled/Disabled

This command sets the date and time in the transmitter. The date and time will be overwritten when a GPS time synchronization occurs. Self-timed transmissions will not occur until the time has been set either using this command or from the GPS. Random transmissions will occur with or without time being set.

The real time clock starts at 01/01/2000 00:00:00 at power up.

F.2.2 Replacement Character Read/Set

Syntax:

IRC=c

Access level: USER

TX320 State: Enabled/Disabled

This command defines the ASCII character that will be substituted for any prohibited ASCII character detected in the transmission data when operating in ASCII or pseudo binary mode. The default character is '*'. Only printable ASCII characters, excluding space, are permitted. In pseudo binary mode, numeric characters are considered illegal.

F.2.3 Save Configuration

Syntax:

SAVE

Access level: USER

TX320 State: Enabled/Disabled

This command directs the transmitter to commit the entered configuration parameters to non-volatile memory. Until this command is entered, the previously saved configuration can be recalled using the RSTR command.

F.2.4 Restore Configuration

Syntax:

RSTR

Access level: USER

TX320 State: Enabled/Disabled

This command directs the transmitter to restore the configuration parameters from non-volatile memory. Changes made to the configuration are not automatically saved to non-volatile memory as they are entered. This allows changes to be made and verified before committing them to permanent storage, but provides the ability to recall the last saved settings, if necessary.

F.2.5 Restore Default Configuration

Syntax:

DEFAULT

Access level: USER

TX320 State: Enabled/Disabled

This command directs the transmitter to set the configuration parameters to their factory default (mostly invalid) values; this essentially clears the operation of the transmitter. This command does not automatically save the cleared parameters to non-volatile memory; the SAVE command must be issued to complete the sequence.

This command does not set the calibration data or serial number to factory defaults.

F.2.6 Enable Transmissions

Syntax:
ETX

Access level: USER
TX320 State: Disabled

This command enables transmissions. The configuration parameters will be checked for validity. If valid, they are saved to non-volatile memory and the transmitter is enabled. The enabled/disabled state of the transmitter is also stored in non-volatile memory so that it will resume operation after a power cycle if it was previously enabled.

Note that the factory default configuration is **not** valid. The factory default parameters must be explicitly overwritten with valid values before transmissions can be enabled.

F.2.7 Disable Transmissions

Syntax:
DTX

Access level: USER
TX320 State: Enabled

This command disables transmissions. Normal scheduling of transmissions is suspended.

Note that the transmitter is automatically disabled if configuration parameters are modified and must be re-enabled with the ETX command to resume transmitting.

F.2.8 Read Configuration

Syntax:
RCFG

Access level: USER
TX320 State: Enabled/Disabled

This command lists all of the configuration parameters. Each parameter is in the same format as if its individual command had been executed.

For Example:
RCFG
NESID=326d31d4
TCH=92
.
.
.

The output from the RCFG command can be captured by the host (in a text file) and used to duplicate the configuration in another unit.

F.2.9 Enable Technician Command Mode

Syntax:

TECHMODE password

Access level: USER

TX320 State: Enabled/Disabled

This command changes the command access level to TECHNICIAN. The access level will not change unless the password is correct.

F.2.10 Enable User Command Mode

Syntax:

USERMODE

Access level: USER

TX320 State: Enabled/Disabled

This command changes the command access level back to USER. No password is required. A power cycle of the transmitter will also return the command access level to USER.

F.2.11 Set GPS Fix Interval

Syntax:

GIN=hh:mm:ss

Access level: USER

TX320 State: Disabled

Default value: 00:00:00

This command sets the GPS position fix interval to the hours, minutes, seconds specified in hh:mm:ss. It can also be used without the '=' sign to report the current value. Valid range of hh:mm:ss is 00:05:00 to 24:00:00. A value of 00:00:00 will disable periodic GPS position fixes although they will still occur at power up and every 24 hours as a side effect of the daily automatic OCXO calibration. The current value of the GPS fix interval is also reported by the RCFG command. The parameter is non-volatile when saved using the SAVE or ETX commands.

F.3 GOES Transmission Configuration Commands

The following commands are used to set the configuration parameters for GOES transmissions. Unless otherwise specified, these parameters have invalid default values and must be set explicitly before transmissions can be enabled using the ETX command. These parameters are stored in non-volatile memory by issuing the SAVE command or will be automatically saved when the transmitter is enabled.

The transmitter is disabled automatically if any of these parameters are modified. Parameters can be read by entering the command without the '=' while transmissions are enabled or disabled. All parameters can be read at the same time using the RCFG command.

F.3.1 Set GOES DCP Platform ID

Syntax:
NESID=xxxxxxx

Access level: USER
TX320 State: Disabled

Sets the transmitter's GOES DCP Platform ID to the hex value xxxxxxxx. Valid range is even hex numbers from 2 to 0xffffffffe.

F.3.2 Set Self-Timed Transmission Channel Number

Syntax:
TCH=ccc

Access level: USER
TX320 State: Disabled

This command sets the channel number (**ccc**) for timed transmissions. **ccc** is the channel number and has a valid range of 0 – 266 for bit rates of 100 and 300 bps and a range of 0 – 133 for a bit rate of 1200 bps.

For 100 bps operation on channels 201 – 266, the transmitter will be configured for international operation. Specifically, the 31-bit international EOT will be used (0x63CADD04) in place of the ASCII EOT, and the preamble will be forced to Long.

Setting the channel number to 0 will disable timed transmissions.

F.3.3 Set Self-Timed Transmission Bit Rate

Syntax:
TBR=bbbb

Access level: USER
TX320 State: Disabled

This command sets the timed transmission bit rate where **bbbb** is the bit rate parameter and has valid values of 100, 300 and 1200 bps.

F.3.4 Set Self-Timed Transmission Interval

Syntax:
TIN=dd:hh:mm:ss

Access level: USER
TX320 State: Disabled

Set interval between timed transmissions to days, hours, minutes, seconds specified in dd:hh:mm:ss. Valid range is 00:00:05:00 to 30:23:59:59.

F.3.5 Set Self-Timed transmission First Transmission Time

Syntax:

FTT=hh:mm:ss

Access level: USER

TX320 State: Disabled

Set the time for the first timed transmission of the day. Valid range is 00:00:00 to 23:59:59. The First Transmission Time is also referred to as the Offset, and is between 00:00:00 and the Self-Timed Transmission Interval.

F.3.6 Set Self-Timed Transmission Transmit Window Length

Syntax:

TWL=xxx

Access level: USER

TX320 State: Disabled

Set the length of the timed transmit window. Length is specified in seconds. Valid range is 5 to 240 seconds.

F.3.7 Enable or Disable Self-Timed Transmission Message Centering

Syntax:

CMSG=Y/N

Access level: USER

TX320 State: Disabled

Center the timed transmission in the assigned window if Y otherwise transmit at beginning of assigned window.

F.3.8 Enable or Disable Self-Timed Buffer Empty Message

Syntax:

EBM=Y/N

Access level: USER

TX320 State: Disabled

If EBM is Y, send "BUFFER EMPTY" message if the buffer is empty at time of transmission. If EBM is N, do not transmit if the buffer is empty.

THIS IS NOT FULLY IMPLEMENTED! CURRENTLY IF BUFFER IS EMPTY AT TRANSMIT TIME A MESSAGE IS WRITTEN TO THE AUDIT LOG IF EBM=Y

F.3.9 Set Self-timed Transmission Preamble Length

Syntax:

TPR=S/L

Access level: USER
TX320 State: Disabled

Set the preamble type for timed transmissions. Valid values are S or L (Short or Long). This setting only applies for 100 bps timed transmissions on channels 1 – 200. All 300 and 1200 bps transmissions use short preamble. All 100 bps transmissions on channels above 200 use long preamble.

F.3.10 Set Self-Timed Transmission Interleaver Mode

Syntax:

TIL =S/L/N

Access level: USER
TX320 State: Disabled

Set the timed transmission interleaver type. Valid values are S, L, or N (Short, Long or None). This setting only applies for HDR timed transmissions, i.e. 300 or 1200 bps.

F.3.11 Set Self-Timed Transmission Data Format

Syntax:

TDF =A/P/B

Access level: USER
TX320 State: Disabled

This command sets the timed transmission format to ASCII, pseudo binary or binary. Valid values are A, P or B. This parameter is used to determine the flag word in 300 and 1200 bps transmissions.

Note: It is the responsibility of the host to ensure the data provided for transmission is in the proper format. ASCII data cannot be transmitted when pseudo binary format is selected. Pseudo binary can be transmitted with ASCII format has been selected.

F.3.12 Set Random Transmission Channel Number

Syntax:

RCH=ccc

Access level: USER
TX320 State: Disabled

This command sets the channel number for random transmissions. **ccc** is the channel number and has a valid range of 0 – 266 for bit rates of 100 and 300 bps and a range of 0 – 133 for a bit rate of 1200 bps.

For 100 bps operation on channels 201 – 266, the transmitter will be configured for international operation. Specifically, the 31-bit international EOT will be used (0x63CADD04) in place of the ASCII EOT.

Setting the channel number to 0 will disable random transmissions.

F.3.13 Set Random Transmission Bit Rate

Syntax:

RBR=bbbb

Access level: USER

TX320 State: Disabled

This command sets the random transmission bit rate where **bbbb** is the bit rate parameter and has valid values of 100, 300 and 1200.

F.3.14 Set Random Transmission Interval

Syntax:

RIN =mm

Access level: USER

TX320 State: Disabled

Set the random transmission randomizing interval to mm minutes. The randomizing interval is the interval in which a random transmission will occur if there is data in the random transmission buffer. The actual transmission time will be random, but on average will occur at this rate. Valid range is 5 to 99 minutes.

F.3.15 Set Random Transmission Randomizing Percentage

Syntax:

RPC =mm

Access level: USER

TX320 State: Disabled

This value determines the range of randomization as a percentage of the randomizing interval. Random transmissions will occur at a uniformly distributed random time within this range and on average occur at the randomizing interval rate. Valid range is 10 to 50%.

For example, for a randomizing interval = 15 (minutes) and a randomizing percentage = 20 (%), then the time between any two random transmissions will be 12 to 18 minutes (15 ± 3 minutes).

F.3.16 Set Random Transmission Repeat Count

Syntax:

RRC =xx

Access level: USER

TX320 State: Disabled

The random transmission repeat count is the number of times a random transmission will be repeated. The random transmissions will occur once every random transmission interval as specified by the randomizing interval. The valid range of this parameter is 0 – 99. For example, a value of 3 will direct the transmitter to send the data in the random buffer 3 times before clearing it. A value of 0 indicates that random transmissions will occur every random transmission interval until the random buffer is cleared by the host.

F.3.17 Enable or Disable Random Transmission Message Counter

Syntax:

RMC=Y/N

Access level: USER
TX320 State: Disabled

If RMC is Y, a random message counter will be included at the beginning of the message, ahead of the user data. If it is N, the random message count will not be included.

F.4 Data Buffer Loading Commands

The following commands are used to manage and store data in the GOES transmission buffers.

F.4.1 Load Self-Timed Transmission Buffer

Syntax:

TDT =XX

Access level: USER
TX320 State: Enabled

This command overwrites the GOES Timed Buffer with the data provided. The TX320 transmitter will insert the 31 bit GOES ID, any header information (for example, HDR Flag byte), and append the EOT so these should not be included in the TDT data. If the timed data format is ASCII or pseudo binary, the transmitter will also insert the correct parity bit for each message character and replace illegal characters with the character specified by the **IRC=c** command before transmission.

Characters that have meaning for the command interface (CR, LF, BS, ESC, '~') must be preceded by a '~' character if they appear in the message data.

The maximum length of the formatted data can be up to 126000 bits, or 15750 bytes.

If there is more data loaded into the buffer than can be transmitted in the assigned transmit window, the message will be truncated.

One minute prior to transmission data is removed from the transmit buffer and encoded for transmission (The **DATA IN BUFFER LED** will go out). If this command is received within 1 minute of the transmission time or during a

timed transmission, the data will not be included in the current transmission but will be buffered for the next interval.

F.4.2 Read Number of Bytes in the Self-Timed Transmission Buffer

Syntax:

TML

Access level: USER

TX320 State: Enabled/Disabled

Returns the number of bytes stored in the timed transmission buffer.

F.4.3 Read the Maximum Self-Timed Message Length

Syntax:

MTML

Access level: USER

TX320 State: Enabled

Returns the maximum number of bytes that can be transmitted with the current timed transmission bit rate, window length, and preamble type.

F.4.4 Clear Self-Timed Transmission Buffer

Syntax:

CTB

Access level: USER

TX320 State: Enabled/Disabled

Clears the timed transmission buffer.

F.4.5 Load Random Transmission Buffer

Syntax:

RDT =XX

Access level: USER

TX320 State: Enabled

This command overwrites the GOES Random Buffer with the data provided. The G5 transmitter will insert the 31 bit GOES ID, any header information (for example, HDR Flag byte), and append the EOT so these should not be included in the RDT data. If the random data format is pseudo binary the transmitter will also insert the correct parity bit for each message character and replace illegal characters with the character specified by the IRC=c command before transmission.

Characters that have meaning for the command interface (CR, LF, BS, ESC, '~') must be preceded by a '~' character if they appear in the message data.

Loading data into the random transmission buffer, triggers the random reporting sequence. Once triggered, the random reporting mechanism will send the data loaded in the buffer for the number of transmissions as specified by the random repeat count. The buffer will be cleared automatically when the number of transmissions specified have occurred.

If the command is received within 1 minute or during a random transmission, the data will not be included in the current transmission but will be buffered for the next one.

If there is more data loaded into the buffer than can be transmitted at the assigned bit rate the message will be truncated.

F.4.6 Read Length of the Message in the Random Transmission Buffer

Syntax:

RML

Access level: USER

TX320 State: Enabled/Disabled

Returns the number of bytes stored in the random transmission buffer.

F.4.7 Read the Maximum Random Message Length

Syntax:

MRML

Access level: USER

TX320 State: Enabled

Returns the maximum number of bytes that can be transmitted at the current random transmission bit rate.

F.4.8 Clear Random Transmission Buffer

Syntax:

CRB

Access level: USER

TX320 State: Enabled/Disabled

Clear the random transmission buffer.

F.5 Status and Other Commands

The following commands are used by the host to determine the status of the transmitter for display and diagnostics purposes. These commands can be entered with transmissions enabled or disabled.

F.5.1 Read Version Information

Syntax:

VER

Access level: USER

TX320 State: Enabled/Disabled

This command returns the transmitter serial number, hardware version number, firmware version number, and GPS module version numbers.

F.5.2 Read Transmission Status

Syntax:

RST

Access level: USER

TX320 State: Enabled/Disabled

This command returns the transmitter state, GPS state, time to next transmission, number of bytes in timed transmit buffer, number of bytes in random transmit buffer, number of times random data has been transmitted, fail-safe status, and supply voltage.

The transmitter responds with:

```

Transmitter: Enabled/Disabled[CR] [LF]
GPS: On/Off[CR] [LF]
RTC: Valid/Invalid[CR] [LF]
Time To Next Tx: dd:hh:mm:ss[CR] [LF]
Timed Message Length: nnnn[CR] [LF]
Next Timed Tx: N/A or mm/dd/yyyy hh:mm:ss
Random Message Length: nnnn[CR] [LF]
Random Message Tx Count: nnn[CR] [LF]
Next Random Tx: N/A or mm/dd/yyyy hh:mm:ss
Fail-Safe: OK/Tripped[CR] [LF]
Supply Voltage: xx.x V

```

F.5.3 Read Last Transmission Status

Syntax:

LTXS

Access level: USER

TX320 State: Enabled/Disabled

This command returns the status of the last transmission. The last transmission could have been a regularly scheduled timed transmission, a random transmission, or a test transmission triggered by a test command.

If a transmission has occurred since the unit was last powered up, the transmitter responds to the command with:

Tx Status: Failsafe Tripped/OK
Tx Type: Timed/Random/Test
Last Tx Length: 30 bytes
Last Tx Start Time: 2004/12/16 23:29:48
Last Tx Stop Time: 2004/12/16 23:29:49
Forward Power: -23.1 dBm
Power Supply: 12.0 V

If a transmission has not occurred since power up, the transmitter will respond with:

No Tx Has Occurred

F.5.4 Read GPS Status

Syntax:

GPS

Access level: USER

TX320 State: Enabled/Disabled

This command returns the current GPS status including satellite numbers and signal strengths in the following format if the GPS is on:

Fix Status: Full Accuracy
Almanac Available: N
PPS Output Stable: N
UTC Offset = 0.000000

Satellite #	Signal Strength
30	10.80
23	no lock
10	4.00
25	1.80
5	6.60
21	no lock
17	6.40
2	6.80

If the GPS is off the command returns:

GPS is off

F.5.5 Read GPS Position

Syntax:

POS

Access level: USER

TX320 State: Enabled/Disabled

This command returns position obtained during the last GPS fix in the following format:

```
Time of fix: dd/mm/yyyy hh:mm:ss [CR] [LF]
Lat: sxx.xxxxx [CR] [LF]
Long: sxxx.xxxxx [CR] [LF]
Alt: xxxxx [CR] [LF]>
```

Where latitude is in degrees, + for N and – for S, longitude is in degrees, + for E and – for W, and altitude is in meters.

If a GPS fix has not yet occurred, the transmitter will respond with: **No GPS Fix[CR][LF]>**

F.5.6 Read Audit Log

Syntax:

RAL

Access level: USER

TX320 State: Enabled/Disabled

The RAL command is used to retrieve the audit log information in the following format:

```
yy/mm/dd hh:mm:ss event message 1[CR][LF]
yy/mm/dd hh:mm:ss event message 2 [CR][LF]
.
.
.
yy/mm/dd hh:mm:ss event message N[CR][LF]>
```

Where: **yy/mm/dd hh:mm:ss** are the date and time that the message was created.
event message x is a short text string describing the event detected.

F.5.7 Read Forward Power

Syntax:

RFWD

Access level: USER

TX320 State: Enabled/Disabled

Returns the current forward power in dBm. This value is updated at the bit rate when transmitting and every 30 seconds when not transmitting.

F.5.8 Read Reflected Power

Syntax:

RRFL

Access level: USER

TX320 State: Enabled/Disabled

Returns the reflected power in dBm. This value is updated at the bit rate when transmitting and every 30 seconds when not transmitting.

F.5.9 Read Power Supply

Syntax:

RPS

Access level: USER

TX320 State: Enabled/Disabled

Returns the power supply voltage in volts. This value is updated at the bit rate when transmitting and every 30 seconds when not transmitting.

F.5.10 Read TCXO Temperature

Syntax:

RTEMP

Access level: USER

TX320 State: Enabled/Disabled

Returns the TCXO temperature (PCB temperature) in degrees C. This value is updated at the bit rate when transmitting and every 30 seconds when not transmitting.

F.5.11 Read Measured Frequency

Syntax:

RMF

Access level: TECHNICIAN

TX320 State: Enabled/Disabled

This command returns the last measured OCXO and TCXO frequencies in the following format:

F-OCXO: 10000005.9000

F-TCXO: 43199.9166

Units are Hz.

Appendix G. Meteosat Transmit Frequencies

Ch No.	Frequency	Bandwidth		Ch No.	Frequency	Bandwidth
1	402035500	1500		46	402103000	1500
2	402037000	1500		47	402104500	1500
3	402038500	1500		48	402106000	1500
4	402040000	1500		49	402107500	1500
5	402041500	1500		50	402109000	1500
6	402043000	1500		51	402110500	1500
7	402044500	1500		52	402112000	1500
8	402046000	1500		53	402113500	1500
9	402047500	1500		54	402115000	1500
10	402049000	1500		55	402116500	1500
11	402050500	1500		56	402118000	1500
12	402052000	1500		57	402119500	1500
13	402053500	1500		58	402121000	1500
14	402055000	1500		59	402122500	1500
15	402056500	1500		60	402124000	1500
16	402058000	1500		61	402125500	1500
17	402059500	1500		62	402127000	1500
18	402061000	1500		63	402128500	1500
19	402062500	1500		64	402130000	1500
20	402064000	1500		65	402131500	1500
21	402065500	1500		66	402133000	1500
22	402067000	1500		67	402134500	1500
23	402068500	1500		68	402136000	1500
24	402070000	1500		69	402137500	1500
25	402071500	1500		70	402139000	1500
26	402073000	1500		71	402140500	1500
27	402074500	1500		72	402142000	1500
28	402076000	1500		73	402143500	1500
29	402077500	1500		74	402145000	1500
30	402079000	1500		75	402146500	1500
31	402080500	1500		76	402148000	1500
32	402082000	1500		77	402149500	1500
33	402083500	1500		78	402151000	1500
34	402085000	1500		79	402152500	1500
35	402086500	1500		80	402154000	1500
36	402088000	1500		81	402155500	1500
37	402089500	1500		82	402157000	1500
38	402091000	1500		83	402158500	1500
39	402092500	1500		84	402160000	1500
40	402094000	1500		85	402161500	1500
41	402095500	1500		86	402163000	1500
42	402097000	1500		87	402164500	1500
43	402098500	1500		88	402166000	1500
44	402100000	1500		89	402167500	1500
45	402101500	1500		90	402169000	1500

Appendix G. Meteosat Transmit Frequencies

Ch No.	Frequency	Bandwidth		Ch No.	Frequency	Bandwidth
91	402170500	1500		141	402245500	1500
92	402172000	1500		142	402247000	1500
93	402173500	1500		143	402248500	1500
94	402175000	1500		144	402250000	1500
95	402176500	1500		145	402251500	1500
96	402178000	1500		146	402253000	1500
97	402179500	1500		147	402254500	1500
98	402181000	1500		148	402256000	1500
99	402182500	1500		149	402257500	1500
100	402184000	1500		150	402259000	1500
101	402185500	1500		151	402260500	1500
102	402187000	1500		152	402262000	1500
103	402188500	1500		153	402263500	1500
104	402190000	1500		154	402265000	1500
105	402191500	1500		155	402266500	1500
106	402193000	1500		156	402268000	1500
107	402194500	1500		157	402269500	1500
108	402196000	1500		158	402271000	1500
109	402197500	1500		159	402272500	1500
110	402199000	1500		160	402274000	1500
111	402200500	1500		161	402275500	1500
112	402202000	1500		162	402277000	1500
113	402203500	1500		163	402278500	1500
114	402205000	1500		164	402280000	1500
115	402206500	1500		165	402281500	1500
116	402208000	1500		166	402283000	1500
117	402209500	1500		167	402284500	1500
118	402211000	1500		168	402286000	1500
119	402212500	1500		169	402287500	1500
120	402214000	1500		170	402289000	1500
121	402215500	1500		171	402290500	1500
122	402217000	1500		172	402292000	1500
123	402218500	1500		173	402293500	1500
124	402220000	1500		174	402295000	1500
125	402221500	1500		175	402296500	1500
126	402223000	1500		176	402298000	1500
127	402224500	1500		177	402299500	1500
128	402226000	1500		178	402301000	1500
129	402227500	1500		179	402302500	1500
130	402229000	1500		180	402304000	1500
131	402230500	1500		181	402305500	1500
132	402232000	1500		182	402307000	1500
133	402233500	1500		183	402308500	1500
134	402235000	1500		184	402310000	1500
135	402236500	1500		185	402311500	1500
136	402238000	1500		186	402313000	1500
137	402239500	1500		187	402314500	1500
138	402241000	1500		188	402316000	1500
139	402242500	1500		189	402317500	1500
140	402244000	1500		190	402319000	1500

Ch No.	Frequency	Bandwidth		Ch No.	Frequency	Bandwidth
191	402320500	1500		241	402395500	1500
192	402322000	1500		242	402397000	1500
193	402323500	1500		243	402398500	1500
194	402325000	1500		244	402400000	1500
195	402326500	1500		245	402401500	1500
196	402328000	1500		246	402403000	1500
197	402329500	1500		247	402404500	1500
198	402331000	1500		248	402406000	1500
199	402332500	1500		249	402407500	1500
200	402334000	1500		250	402409000	1500
201	402335500	1500		251	402410500	1500
202	402337000	1500		252	402412000	1500
203	402338500	1500		253	402413500	1500
204	402340000	1500		254	402415000	1500
205	402341500	1500		255	402416500	1500
206	402343000	1500		256	402418000	1500
207	402344500	1500		257	402419500	1500
208	402346000	1500		258	402421000	1500
209	402347500	1500		259	402422500	1500
210	402349000	1500		260	402424000	1500
211	402350500	1500		261	402425500	1500
212	402352000	1500		262	402427000	1500
213	402353500	1500		263	402428500	1500
214	402355000	1500		264	402430000	1500
215	402356500	1500		265	402431500	1500
216	402358000	1500		266	402433000	1500
217	402359500	1500		267	402434500	1500
218	402361000	1500		268	402002500	1500
219	402362500	1500		269	402004000	1500
220	402364000	1500		270	402005500	1500
221	402365500	1500		271	402007000	1500
222	402367000	1500		272	402008500	1500
223	402368500	1500		273	402010000	1500
224	402370000	1500		274	402011500	1500
225	402371500	1500		275	402013000	1500
226	402373000	1500		276	402014500	1500
227	402374500	1500		277	402016000	1500
228	402376000	1500		278	402017500	1500
229	402377500	1500		279	402019000	1500
230	402379000	1500		280	402020500	1500
231	402380500	1500		281	402022000	1500
232	402382000	1500		282	402023500	1500
233	402383500	1500		283	402025000	1500
234	402385000	1500		284	402026500	1500
235	402386500	1500		285	402028000	1500
236	402388000	1500		286	402029500	1500
237	402389500	1500		287	402031000	1500
238	402391000	1500		288	402032500	1500
239	402392500	1500		289	402034000	1500
240	402394000	1500				

Campbell Scientific Companies

Campbell Scientific, Inc.

815 West 1800 North
Logan, Utah 84321
UNITED STATES

www.campbellsci.com • info@campbellsci.com

Campbell Scientific Canada Corp.

14532 – 131 Avenue NW
Edmonton AB T5L 4X4
CANADA

www.campbellsci.ca • dataloggers@campbellsci.ca

Campbell Scientific Africa Pty. Ltd.

PO Box 2450
Somerset West 7129
SOUTH AFRICA

www.campbellsci.co.za • cleroux@csafrica.co.za

Campbell Scientific Centro Caribe S.A.

300 N Cementerio, Edificio Breller
Santo Domingo, Heredia 40305
COSTA RICA

www.campbellsci.cc • info@campbellsci.cc

Campbell Scientific Southeast Asia Co., Ltd.

877/22 Nirvana@Work, Rama 9 Road
Suan Luang Subdistrict, Suan Luang District
Bangkok 10250
THAILAND

www.campbellsci.asia • info@campbellsci.asia

Campbell Scientific Ltd.

Campbell Park
80 Hathern Road
Shepshed, Loughborough LE12 9GX
UNITED KINGDOM

www.campbellsci.co.uk • sales@campbellsci.co.uk

Campbell Scientific Australia Pty. Ltd.

PO Box 8108
Garbutt Post Shop QLD 4814
AUSTRALIA

www.campbellsci.com.au • info@campbellsci.com.au

Campbell Scientific Ltd.

3 Avenue de la Division Leclerc
92160 ANTONY
FRANCE

www.campbellsci.fr • info@campbellsci.fr

Campbell Scientific (Beijing) Co., Ltd.

8B16, Floor 8 Tower B, Hanwei Plaza
7 Guanghua Road
Chaoyang, Beijing 100004
P.R. CHINA

www.campbellsci.com • info@campbellsci.com.cn

Campbell Scientific Ltd.

Fahrenheitstraße 13
28359 Bremen
GERMANY

www.campbellsci.de • info@campbellsci.de

Campbell Scientific do Brasil Ltda.

Rua Apinagés, nbr. 2018 – Perdizes
CEP: 01258-00 – São Paulo – SP
BRASIL

www.campbellsci.com.br • vendas@campbellsci.com.br

Campbell Scientific Spain, S. L.

Avda. Pompeu Fabra 7-9, local 1
08024 Barcelona
SPAIN

www.campbellsci.es • info@campbellsci.es

Please visit www.campbellsci.com to obtain contact information for your local US or international representative.